

Keywords: relieving construction; temporary viaduct;
Bridge; mining area; damage; railway line

Piotr BĘTKOWSKI

Silesian University of Technology, Faculty of Civil Engineering
Akademicka 5, 44-100 Gliwice, Poland
Corresponding author. E-mail: piotr.betkowski@polsl.pl

STEEL RELIEVING CONSTRUCTIONS IN MINING AREAS AS TEMPORARY OR PERMANENT RAILWAY BRIDGES

Summary. This article describes three examples of bridge-type relieving constructions located on railway lines in the areas of active mining exploitation. It discusses how to take into account mining influences and how to support a temporary relieving construction on the railway embankment. This article discusses the incorrect solutions and their consequences. The first example involves the protection of train traffic continuity during the replacement of bridge span under an intensively used railway line. The second example shows the incorrect use of the relieving construction, leading to the relaxation of soil ground base and failure of a small brick arch railway bridge. The third example describes the use of the relieving construction as a permanent span of the railway bridge located in the area where mining subsidence is over 14 m. The railway line is located on the third bridge; it is a single-track line, which is the only way to transport coal and equipment needed for operation in a large underground coal mine; interruptions of railway traffic longer than 4 working days (5 consecutive days) are unacceptable. This article has basic information about the effects of mining impacts, bridge-type steel relief constructions and a theoretical introduction enabling analysis of interactions of temporary supports and embankment in mining areas. All examples, especially the third one, contribute to development of knowledge in the field of civil engineering and transport.

1. INTRODUCTION

Mining area is a terrain where the adverse consequences of mining works (e.g. land surface deformations) carried out by underground coal mine are revealed. The boundaries of the mining area are determined by the concession for mining operations. In the mining area, various kinds of damage to buildings may occur. These damages are caused by mining area deformations. Bridges located on railway lines are susceptible to mining influences, e.g. [1÷6]. In bridge constructions with spans based on bearings, the mutual position of rigid solids forming the bridge may change (abutments, spans, pillars) [1, 2]. In frame structures or fixed arches, as a result of mining deformation of the ground, additional internal forces are generated, e.g. [3, 4] – these forces can lead to considerable stress, and as a result of these forces, damages to the bridge structures can occur.

As a result of mining exploitation, the area settles and mining hollows of subsidence are formed – the hollow adversely changes the geometry of the railway line (e.g. [1, 2, 6]). Practically in the entire area of mining subsidence hollow, the area is tilted by uneven settlement, which adversely affects the performance parameters of the track, e.g. in the case of a slope of more than 20‰, there may be a "break" of wagons; it may also be necessary to use the second locomotive to push the rolling stock (wagons), which increases the cost of transport (e.g. [3 - 5]). Therefore, in mining area, the railway track often is raised to restore its correct gradeline.

This article describes three examples of using the railway bridge-type relieving constructions consisting of two full steel girders. Such steel relieving constructions of bridge type are often made in Poland (Poland is the country of the author of this article) (e.g. [3, 4, 7, 8]) but also in many other countries (e.g. [9, 10]).

Railway bridge-type relieving construction, according to the BN-73/89390-04 standard [11], is a steel portable structure placed on the track for a specified (rather short) period of time, playing the role of a temporary bridge span. Such constructions are successfully used, e.g. during the reconstruction of railway bridges and modernization of railway lines to modern standards (e.g. [7, 8]). In the case of reconstruction of the railway bridges, it is practically impossible to guide the detours (bypass) in a manner known from the car road, it is generally necessary to carry out construction works in such a way that continuity of rail traffic can be maintained [12].

Bridge-type relieving constructions can be placed on permanent supports (abutments, pillars), wooden yokes, wooden cushions and other spatial constructions made of wooden train track underlays (according to [11]). Most often, the steel relieving construction is based on wooden underlays arranged in one layer or cages from underlays; these elements are placed on a concrete slab located directly on the embankment. The steel structure placed on wooden elements must be protected against transverse displacement at both its ends and against longitudinal displacement at one end ([11]). Of course, the stability of cages from wooden sleepers should also be checked. Bridge-type relieving constructions should pass receiving (inspection) tests as any other railway bridge, i.e. a test load (e. g. [7, 8]).

As a result of mining area deformations, bridges may be damaged on a scale practically unprecedented outside of mining areas; therefore, typical repair methods (e. g. 12, 13]) are not applicable. In crisp and continuous bridge constructions such as, for example, old brick arches or frame structures, cracks may occur in a very short period of time, endangering the continuity of the structure and requiring the closure of the bridge for railway traffic (e. g. [3, 4]). In typical railway bridges with freely supported spans (recommended solution in mining areas [2, 14]) as a result of area stretching, bridge span may fall from the abutment and, as a result of compressing of terrain, bridge span may be jammed, the backwall and the wingwalls are cut and the track behind the abutment may be subjected to sudden unexpected large deformation (e.g. [1]).

Very often, during construction works (rebuilding, reconstruction, renovation), it is necessary to ensure the continuity of railway traffic. Irrespective of the static scheme of the bridge or the type of damage of the bridge structure, the fastest method of overturning (or maintaining) the rail traffic is to use a bridge-type relieving construction (in Polish reality). Closing the railway line for a certain section causes the extension of the time and route of travel for rolling stock and significant problems in control of railway traffic [15].

In many countries in the world, railway bridges are designed with the possibility of rapid replacement (e. g. [16 - 18]). In Poland, the government does not introduce such programs in mining areas; therefore, unfortunately, the classic reconstruction/rebuilding of the bridge object usually takes several months. Railway bridges may also be damaged as a result of derailment of rolling stock or vehicle impacts [10]; significant mining deformations of the railway tracks or roads cause an increase in this type of accidents in mining areas in relation to the rest of the Polish territory.

The article is inspired by the need to show important problems arising from improper supports of relieving constructions in mining areas; it focuses on interaction of the temporary steel construction with the deforming ground-substrate and on the technical aspects. The errors of support described in this publication result from the lack of relevant entries in Polish technical regulations [14] and the lack of literature publications in this respect. The described solutions have some features of the experiment, all relieving constructions were observed regularly [3, 4] and geodetic measurements were also carried out (long-term observations). Theoretical foundations of the analysis are presented in the article, enabling the correct determination of horizontal forces resulting from mining area deformations; these horizontal forces act on the support and on the railway embankment. This article describes three examples of the use of the relieving construction: (a) during the reconstruction of a bridge damaged as a result of mining operation, (b) as a relief of a seriously damaged small bridge and (c) as a fixed (“permanent”) span of a railway bridge. Real project solutions are described; attention is paid to principles of computational analysis and technical problems that should be solved.

2. BRIDGE-TYPE RELIEVING CONSTRUCTION AND MINING AREA DEFORMATIONS

In the Polish technical literature on railway bridges in mining areas [1, 2, 11, 14, 19] there is no information on the impact of mining terrain deformations on the relieving construction and what factors cause mining deformations in the situation when the relieving construction is based on wooden cages or on wooden sleepers (wooden cushion). Such support does not provide the same kinematic freedom, as classic bridge bearings. A horizontal force T_f arises due to steel friction (relieving construction) against wood. Such horizontal force may arise as a result of the displacement of the supports relative to the steel span (due to mining surface deformations ε , changes in span length due to temperature changes) and depends directly on the weight of the structure with the equipment and the weight of the railway rolling stock on the bridge span. T_f force can be written as (1):

$$T_f = \mu \cdot N, \quad (1)$$

where T_f – friction force; $\mu=0.5$ – steel–wood static friction coefficient; and N – support vertical force.

Estimation of the effects of this horizontal force T_f requires an extended stability analysis of the embankment (e.g. FEM, Bishop's method). The analysis should take into account the possibility of changing the parameters of the soil ground (loosening the soil substrate) as a result of mining stretching of the area. According to the author's own measurements (not published in the literature), the degree of non-cohesive soil compaction I_d may even decrease by 20% (depending on the category of mining area, generally about 5-10% for typical mining area deformations in a period of 10 years).

Supports of the relieving construction move along with the mining subsoil; it should be taken into account through the appropriate width of the expansion joints, e.g. between the steel span and the wooden vertical backwall protecting the embankment. A good estimation of horizontal displacements is given by Prof. Rosikoń formulas (e.g. [2]), in which displacements are determined depending on the location of the mining front of exploitation: in the axis of the viaduct and oblique to the bridge object. In the case of relieving constructions, i.e. narrow and long structures, the horizontal displacement described by formula (2) is generally decisive (according to [2]):

$$\Delta l_p = \pm \left(\varepsilon + \frac{H}{R} \right) \cdot l, \quad (2)$$

where Δl_p - longitudinal displacement of the support relative to the span in *mm*, l - span in *m*, which is equal to the distance l_p between the centers of gravity of the foundation fields, H - height of the support in *m*, R - radius of curvature in *km* and ε - value of horizontal unit deformation of the substrate in *mm/m*.

In railway regulations for bridges (Technical Standards [14]) and maintenance (ID-16 [19]), there is no information on the relieving constructions in mining areas. Railway regulations (Technical Standards [14]) only provide very general information that the construction of engineering structures in the mining exploitation area should ensure in particular: freedom of displacement of structural elements, i.e. displacements of span with respect to supports (simply supported beam scheme) and possibility of rectifying the position of structural elements. The provisions on inspections contained in the "Instruction for maintenance of railway (...) structures (...) ID-16" [19] are insufficient; additional inspections, observations and measurements are necessary, as pointed out in this article.

3. EXAMPLES OF BRIDGE-TYPE RELIEVING CONSTRUCTIONS LOCATED IN MINING AREAS

3.1. Protection of the continuity of rail transport during the rebuilding of the bridge

The example of the use of the relieving construction to protect the continuity of railway traffic during the rebuilding of the bridge is described below. This small bridge integrates with the railway embankment (horizontal side wall distance: approx. 5m).

To the reconstruction, which began in July 2011, old bridge consisted of two parts of separate constructions. These constructions were assigned to individual tracks: under No. 1 track, there was a

brick (masonry) arch and under track No. 2, the reinforced concrete frame structure was located. The railway line was electrified. One of these bridges, placed under track No. 1, failed due to mining influences. It was necessary to rebuild this bridge. The rebuilding consisted of two stages: the demolition of the old brick arch bridge and building of a new one. The new bridge had a static scheme of a closed frame and was connected to the bridge in track No. 2. A description of damages of these bridges and an example of analytical calculations, including mining interactions between the ground and the bridge structure, are given in [4].

According to the designer's agreement with PKP PLK, it was impossible to close the railway track. It was necessary to use two bridge-type relieving constructions. One relieving construction was placed over the rebuilt bridge in track No. 1 and the other on the adjacent track because, during rebuilding of this object, it was necessary to remove part of the ballast from the top plate of the bridge under track No. 2 (Fig. 1). Typical, ready-made relieving constructions type KO-21/73 (theoretical span 21 m) based on wooden sleepers (wooden cushion) were used. Wooden foundations were placed on the prefabricated reinforced slabs with dimensions of 1.50x3.00 m; these slabs were placed directly on the embankment.



Fig. 1. View of the track on the bridge, visible two relieving constructions built in both tracks

During earthworks (excavations), daily geodetic measurements were made at four control points. The control points were located on both sides of the constructions, on both sides of the prefabricated slabs located on the railway embankment (in the axis of support). During the 7-month period from the demolition of the old bridge to the commissioning of a new facility for use, small stretching dominated in the subsoil; the area settled 18.7 cm at one end of the relieving constructions and 17.3 cm at the other end (track No. 1).



Fig. 2. View of relieving constructions during the rebuilding of the bridge

In the case of mining stretching of the rear, the horizontal force resulting from the friction between the support and relieving construction acts in the direction of the embankment slope and this force has to be transferred (taken over) by the retaining wall. In this example, the friction force calculated from formula (1) was around 200 kN. In this example, the frontal wall of the escarpment was not initially correctly protected, deformations appeared on the front of the escarpment (in its upper part) and the relieving construction began to settle quickly (3 cm/day). Thanks to geodetic measurements and daily observation (shape control) of the scarps forehead, no catastrophe occurred, but track No. 1 needed to be closed for a few days. The “Berlin wall” was made (steel I-beams pushed into a suitable depth into the substrate and concrete slabs as a filling of the space between I-sections); this “Berlin wall” is visible in Fig. 2. After protecting the slope, the relieving construction was used without restrictions.

3.2. Protecting the continuity of rail transport over the damaged bridge

The use of the bridge-type relieving construction to protect the continuity of railway traffic over the damaged bridge is described below. The relieving construction (type KO-21/73) was built into track No. 1 for a period of about 8 years, until the rebuilding of this railway bridge. As a result of mining exploitation, this small brick bridge with a track over the structure was severely damaged (Fig. 3).



Fig. 3. View of the bridge from the level of the local road

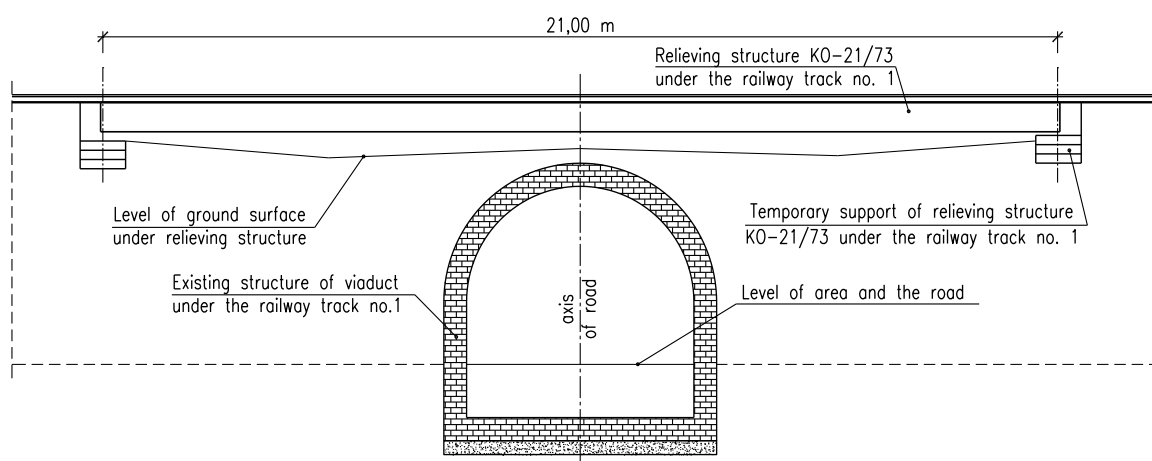

Fig. 4. Relieving construction built in a railway track

In bridge components with a hyper-static structure, considerable internal forces are often generated as a result of the bridge's interaction with the ground surface deformations caused by mining exploitation. This bridge is a crisp arch, not designed to carry mining influences (during the construction of the bridge in 1910, no mining operations were carried out in this area). The

construction material is an ordinary full brick. Horizontal light (between walls) at the road level is 5 m vertical light (from vault to road): 3.9 m [3].

One of the effects of mining exploitation was also the reduction of the degree of non-cohesive soil compaction I_d in the embankment by approx. 7% during these 8 years (subsidence of the area approx. 1.8 m, mining terrain expansion (stretching) $e=3\text{mm/m}$).

The theoretical length of the span of the relieving construction is 21 m and the total length is 21.60 m (Fig. 4). The relieving construction was based on both ends on prefabricated slabs (made of reinforced concrete) via old wooden railway sleepers. Reinforced concrete slabs with dimensions of $1.50\text{m}\times 3.00\text{m}$ were laid on the embankment. A compacted layer of sand was made under the slabs.



Fig. 5. View of the bridge with a built-in relieving construction

The relieving construction correctly protected the continuity of railway traffic (Fig. 5), but contributed to the failure of the masonry arch (Fig. 3).

Supports of the relieving construction based on the embankment led to the creation in the ground the so-called negative vault above the arch (e.g. [3]). In a short period of time (6 month), numerous multidirectional cracks appeared and also through the entire brick arch, there was irreparable damage and division of the structure on loose solids (due to scratching). There was total loss of carrying capacity. Interestingly, damage to the wingwalls at that time was practically unchanged, and mining influences during 6 months after installing the relieving structure were very small. It should be noted that already before the assembly of the relieving construction, the bridge was severely scratched, but until the relieving construction was installed, rail traffic was carried out on the bridge (with a limited speed to 30 km/h due to track deformation – mining damage).

To ensure the safety of users of the municipal road running under the bridge, the brick structure was provisionally protected with a steel mining enclosure "ŁP" with filling (with concrete blocks) space between this steel enclosure and brick (e. g. Fig. 3).

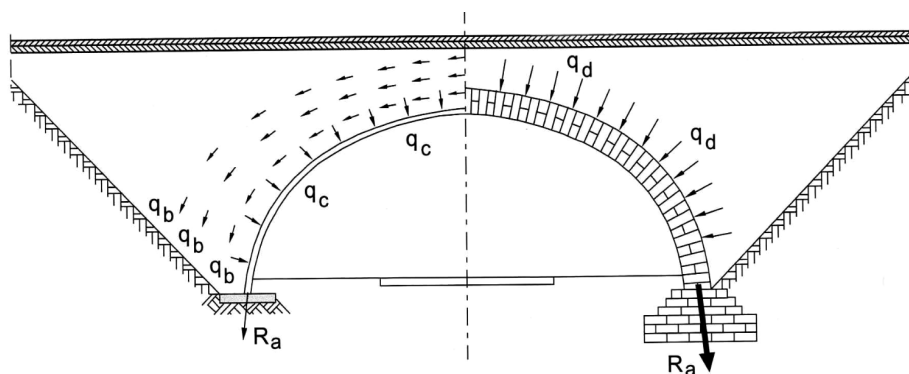

Fig. 6. Interaction of the soil–ground vault with the susceptible structure q_b and with the stiff structure q_a

The main reason for failure of the arch structure was not mining influences, but the relieving of the arch. The soil outside the arch was compression as a result of the installation of the relieving construction. But over the arch, instead of squeezing, the ground was stretched. The favorable effect of the soil-ground vault, which relieves with the arch structure, susceptible to minor scratches, has protected this structure for years against the influence of significant mining exploitation. The scheme (mechanism) of flexible and rigid soil-ground vault is shown in Fig. 6 (R_a - support reaction; q_b - stream of compressive forces in the ground vault, relieving with flexible arch; q_c - soil interaction on a flexible arch; and q_d - load acting on the rigid arch, where q_d is always greater than q_c).

3.3. Bridge-type relieving construction as a fixed (permanent) span of a railway bridge

Below, the railway bridge is described, whose reinforced concrete span (approx. 11.5 m, static scheme of a free-supported beam) has been replaced with a 30 m long relieving construction, based on the embankment. This bridge-type relieving construction for 6 years (May 2013 ÷ July 2019) has served as the permanent span of the railway bridge.

Since the building of this bridge at the end of the 1960s until April 2013, the bridge settled approximately 13.6 m. At the beginning of May 2013, during the weekend spanning two holidays (1th and 3rd May), the bridge-type relieving construction was built on the track. Currently (July 2019), total settlement of the area is 14.7 m.

In the past, the large inclination of the slope of the mining hollow (over 20‰ before the rebuilding) made the flow of railway traffic in the area of the bridge difficult. Due to the risk of breaking the connections of wagons, it was necessary to use two locomotives, one of which pushed the train.

In the past, several times, the concrete span of the bridge was lifted; the level of the road under the bridge was also raised. Raising track grade level on the bridge required: carrying out a construction project, obtaining a building permit, performing expensive works related to the lifting of the span, superstructure of the back walls and wing-walls, raising the level of the track outside the bridge. As a result of the construction works carried out (including the elevation of the road under the bridge over 5 m), a significant part of the original construction of the bridge was underground. The abutments approached each other by about 0.40 m, and the deflection of each of the abutments toward the span exceeded 0.10 m; these displacements were similar to those calculated from formula (2), which is presented in this article. At some point in the past, the span was jammed and an emergency reconstruction was necessary: the walls were displaced (dismantled and built in a new location).

Until the end of April 2013, the railway track ran above the local road on a reinforced concrete bridge (dating from the early 1960s). This bridge was a single-span structure with a static scheme of a simply supported beam (Fig. 1). The width of the bridge in the horizontal light was 10.35 m and the height in the vertical light was 8.15 m (April 2013).

The bridge was raised many times, along with adjacent tracks. The rectification consisted of lifting the reinforced concrete span through the superstructure of the abutments. The frontal wall of the bridgehead was constantly (several times) raised; thus, the pressure of the ground on the abutments wall also increased. The supports were lifted by adding prefabricated elements, 0.60 m high each, connected to each other and supported by reinforced concrete. Such a connection has never been fully monolithic. Numerous small oblique scratches combined with long, deep cracks running through the entire wings indicated the exhaustion of the reserve capacity of the wings; hence, further raising the wing walls was not recommended. Due to the approach of bridgeheads and their increasing deflection (threat of loss of stability), the mine decided to rebuild the bridge. The reconstruction was also supposed to ensure the increase of the track level by more than 2.5 m and provide the possibility of raising the track by 6 m in the future. All works had to be logistically organized in such a way that the closure of the track would not exceed 5 days [20] because the single track running along the bridge is the only railway connection necessary for the proper functioning of the large mine.

Several variants of this bridge rebuilding were analyzed [20] (all analyzed variants are described in a publicly available publication [20]). However, due to the high costs of rebuilding, it was finally decided to install the relieving construction, which was longer than old bridge. This construction was based directly on the embankment. Long relieving construction takes the load from the abutments and

assumes horizontal forces from the braking of the rolling stock. This improves the stability of the abutments, which, after dismantling the concrete span, function as retaining walls. A huge advantage of this solution is the possibility of easy, smooth and cheap lifting of the structure, which means that lifting of the level of the track can be carried out more often and with smaller jumps.

The old reinforced concrete span was dismantled at the end of April 2013 (Fig. 7). Two days later, a new steel span (relieving construction) was placed on the embankment (Fig. 8).

The relieving construction has been individually designed in accordance with the standard [11]. The length of the span (in the axes of the supports) is $L_t = 30.00$ m.

The relieving construction is based directly on the embankment. There is a large point load on the embankment. According to the ground tests that were carried out, the embankment was built, from a depth of 3 m to a depth of 10 m, with the ground characterized by the degree of soil compaction I_d from 0.3 to 0.7. These are weak, compressible soils. There was a real risk of "squeezing" the weaker layer from between the stronger layers – stresses in the embankment are decomposed in the ground at a small angle (about 15%) and move from the top to the base of the embankment through all layers.



Fig. 7. View of the bridge with the old reinforced concrete span (April 2013)



Fig. 8. View of the bridge with steel relieving construction (May 2013)

The local dislocation of the weaker soil (also compression during the passing of the rolling stock) could lead to the loss of stability of the larger part of the embankment. The slope stability analysis was performed using the global stability factor method “ F ” (determining the Bishop's slip-line lines; in the case of embankments, this method gives good results quickly) (Fig. 9). Global stability factor F must be greater than a certain limit value; then, the stability of the embankment is ensured [21]. This approach in stability analysis is often used for railway embankments. The values of global stability factors, still used and required by the railway regulations in Poland (e. g. [22]), are as follows:

- new railways: $F = 2.0$,
- operated railways: $F = 1.5$ and
- railways immediately after repair: $F = 1.3$.

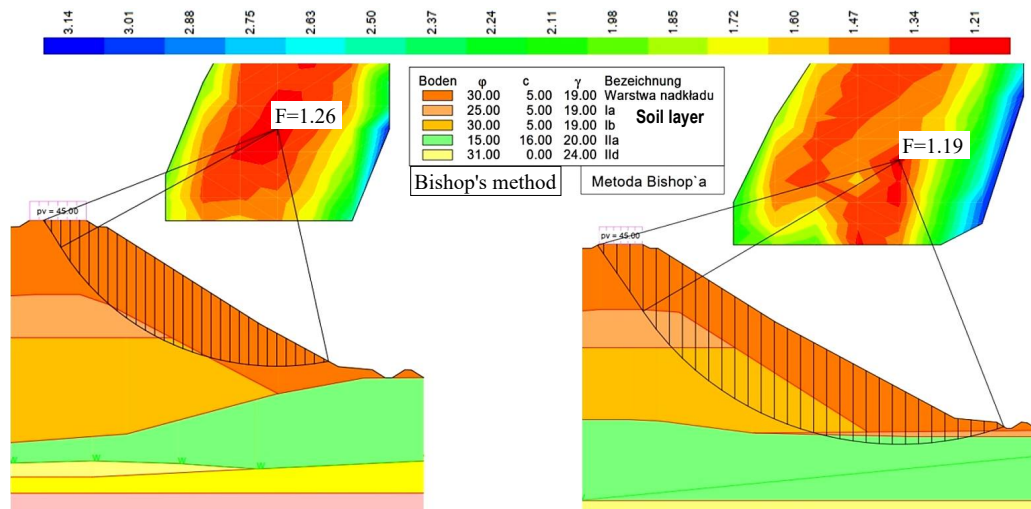

Fig. 9. Slope stability analysis of embankment under supports of relieving construction - Bishop's method

The railway embankment is made of mine slate, i.e. a relatively weak material. Clay sands lie under the embankment. The material from which the embankment is made has a significant impact on the load-bearing capacity and stability of its entire structure (e. g. [23]). The railway embankment was widened and was strengthened with geo-synthetics on the sections, being within the range of the impact of the loads from structure supports (in April 2013). The use of synthetics geo-meshes and geogrids to reinforce embankments in mining area is an effective solution (e. g. [6]).

The analyses took into account the specificity of mining areas, e.g. 15% lower soil-ground parameters (I_d). Of course, the soil parameters were first investigated, holes (boreholes) at a depth of 15 m were made in the embankment on each side of the bridge (January 2013). Full geotechnical studies were carried out. In the slope stability analysis, the horizontal force resulting from the friction between the relieving construction and the support was taken into account. In this example, the friction force calculated from formula (1) was around 500 kN.

Modeling subsoil interaction with this type of temporary bridge object is often more complicated than modeling the steel construction itself. Temporary supports cannot settle in relation to the embankment and cannot cause destruction of the embankment (e.g. [24]).

The relieving steel construction is based on both sides on wooden sleepers; the sleepers are based on a concrete slab (Fig. 10). The bridge back-walls are also made of wooden elements. There are no bridge bearings and expansion joints. Due to the lack of classic fixed (permanent) bridge bearings and due to track deformations on the embankment outside the bridge (mining damage), the speed of rolling stock is limited to 20 km/h. Friction force between the steel relieving construction and the temporary wooden support ensures the span's stability.



Fig. 10. Relieving construction into the railway, wooden sleepers and temporary wooden back-walls

After assembly of the new span, regular inspection was carried out according to the procedure made by the designer. Once a week visual inspection is performed and once a month geodetic measurement are carried out. This structure is still located in an active mining area. In the period from May 2013 (incorporation of the relieving construction into the track) to the end of July 2019, the area settled about 1,1 m. Bridge abutments separated from each other (move away) about 40 mm. There was also a small inclination of the bridgeheads of about 2 mm.

Over the last six years, the relieving construction and old bridgeheads "worked" correctly, without major uncontrolled displacements. Currently (July 2019), preparatory work is underway to raise the relieving construction and track gradeline.

4. CONCLUDING REMARKS

Bridge objects are often damaged as a result of large mining area deformations. In Poland, in mining areas, bridge structures were not designed for rapid replacement. Typical reconstruction of a railway bridge usually takes a period of several months. It is necessary to ensure continuity of rail traffic. A good solution is to use the steel relieving construction, and build into the railway track as a temporary bridge.

The relieving construction works in the static scheme of the simply supported beam. This construction is easy to rectify. Flexible embankment dissipates energy arising from mining shocks. All these factors make that resistance of the relieving construction to mining influences is correct, this resistance is adapted to the predicted mining area deformations.

This article describes three practical examples of the use of steel relieving constructions in areas of active mining exploitation. Problems resulting from the appearance of mining deformations on the surface of the terrain are shown. It is discussed what real threats should be taken into account for relieving constructions in the three most common situations in mining areas: short-term use during the rebuilding of the bridge, long-term use as a relief of seriously damaged the small railway bridge (period of several years) and as the target span of the railway bridge intended for permanent grade lifting (elimination of impediments in the operation of traffic: large declines resulting from the formation of a mining subsidence hollow). The basic theoretical relations helpful in the analysis of the interaction of the relieving construction with the deforming substrate are also given.

In mining areas, bridge-type relieving constructions are often based on embankments on a concrete slab by means of cages made of wooden sleepers or directly on wooden sleepers (wooden cushion). In such cases, horizontal friction forces are generated proportional to the weight of the relieving construction with the equipment and possibly the weight of the rolling stock on the structure. The frictional force is revealed during diurnal temperature changes (often changing the direction in the diurnal cycle) and arises as a response of the structure to the displacement of supports due to mining ground compression/stretching (the direction of such force is constant, e.g. in the case of ground creep-age/stretching, the force is directed toward the front of abutment). This force is transferred to the embankment and should be considered in the analysis of the stability of embankments and bridgeheads. It is also necessary to take into account the influence of mining deformations on the width of expansion joints between the construction and the back wall, so that the construction should not be jammed.

The bridge-type relieving construction based not far from the arch span integrated into the embankment may cause such important changes in stresses in the embankment, which will lead to the destruction of the arch structure due to excessive stretches. Analyses (e. g. FEM models) are especially required in the case of masonry (e.g. brick) girders, where the low rigidity of the structure (reduced as a result of the slow long-term development of scratches) led to the creation of soil-ground vault, which co-operates with the construction.

All substrate models should take into account the possibility of changing the parameters of the soil-ground center as a result of mining area compression/stretching and the inhomogeneity of the construction of the embankment. Ground soil tests are necessary.

The last example described in the article is especially interesting and innovative. The relieving construction with a span of 30 m works (serves) as a permanent span of the railway bridge. This construction is located directly on the embankment. The designed location of supports of the construction far away from existing bridgeheads significantly relieves bridgeheads (e. g. from the rolling stock loads). It is possible to raise the level of the track along with the relieving construction even by more than 6 m, safe for existing damaged reinforced concrete abutments.

In all cases, regular observations (visual inspection) and geodetic measurements were carried out, which allowed for appropriate preventive actions (e.g. the first example describes the construction of the "Berlin wall" to ensure adequate slope stability).

References

1. Salamak, M. *Obiekty mostowe na terenach z deformującym się podłożem w świetle kinematyki brył*. Wydawnictwo Politechniki Śląskiej, Gliwice. 2013. 228 p. Available at https://www.researchgate.net/publication/256839657_Obiekty_mostowe_na_terenach. [In Polish: *Bridge structures located on areas with ground deformations in the light of solids kinematics*].
2. *Wytyczne techniczno-budowlane projektowania i wykonywania obiektów mostowych na terenach eksploatacji górniczej*. Ministerstwo Komunikacji. 1977. 43 p. [In Polish: *Technical and construction guidelines for design and construction of bridge objects in mining areas*].
3. Bętkowski, P. Conclusions from observation the small crisp arch bridges located on mining areas. *Procedia Engineering*. 2016. Vol. 161. P. 687-692. DOI.org/10.1016/j.proeng.2016.08.738.
4. Bętkowski, P. Analysis of Mining Influences on a Small Frame Railway Viaduct. *IOP Conference Series: Earth and Environmental Science*. 2019. Vol. 362(012142). P. 1-10. DOI: 10.1088/1755-1315/362/1/012142.
5. Wen, Qing Jie & Lu, Hui. Bridge Disaster Prevention and Disposal Methods in Mining Area. *Applied Mechanics and Materials*. 2012. Vol. 204-208. P. 3494-3498. DOI: 10.4028/www.scientific.net/AMM.204-208.3494.
6. Surowiecki, A. & Piotr Sask, P. & Ksiadzyna, K. & Ryczynski J. Traffic infrastructure in mining areas (selected problems). *Scientific Journal of the Military University of Land Forces*. 2019. Volume 51. Number 3(193). P. 558-578. DOI: 10.5604/01.3001.0013.5010.
7. Graczyk, M. & Woch, M. & Skulski, B. Construction of railway bridges made of flexible structural plates. Live load test. *Archives of Institute of Civil Engineering*. 2017. Vol. 23. P. 117-124. DOI: 10.21008/j.1897-4007.2017.23.11.
8. Chróścielewski, J. & Banaś, A. & Malinowski, M. & Miśkiewicz, M. Kolejowe konstrukcje odciążające typu mostowego w świetle badań in situ i analiz teoretycznych. *Archiwum Instytutu Inżynierii Lądowej*. 2011. No. 10. P. 39-54. Available at: https://www.researchgate.net/publication/309683184_Kolejowe_konstrukcje_odciazajace_typu. [In Polish: Railway relieving constructions of bridge type in the light of situ research and theoretical analysis].
9. Eum, Ki-Y. & Bae, J.-H. & Choi, Ch.-Y. Evaluation of Train Running Safety During Construction of Temporary Bridge on Existing Railway. *Journal of the Korean Society for Railway*. 2011. Vol. 14. No. 3. P. 234-239. Available at: <http://koreascience.or.kr/article/JAKO201129362564137.page>.
10. Special Topics Report. *Railway Bridges in Ireland & Bridge Strike Trends*. Railway Safety Commission. 2009. 121 p. Available at: <https://www.crr.ie/assets/files/pdf/bridgestrikesireland1>.
11. BN-73/8939-04. *Konstrukcje odciążające pod czynnymi torami kolejowymi*. Wydawnictwa Normalizacyjne. 1973. 5 p. Available at: <http://bc.pollub.pl/dlibra/publication/5420/edition/5051?language=pl>. [In Polish: *Relieving constructions under active railway tracks*].
12. Frangopol, D. & Tsompanakis Y. *Maintenance and Safety of Aging Infrastructure: Structures and Infrastructure*. Book Series. Vol. 10. CRC Press, New York, US. 2014. 746 p.

13. Railway Guideline. *Deliverable 1.3: New technologies to extend the life of elderly rail infrastructure. Maintenance, renewal and Improvement of rail transport infrastructure to reduce Economic and environmental impacts* (Project co-funded by the European Commission within the 7th Framework Programme - several European countries participated). ARTTIC. 2014. 194 p. Available at: www.mainline-project.eu › IMG › pdf › ml-d1.3-f-new_technologies.
14. *Standardy Techniczne: szczegółowe warunki techniczne dla modernizacji lub budowy linii kolejowych do prędkości $V_{max} \leq 200$ km/h (...) / 250 km/h (...)*. Vol. III: Bridge objects. Warszawa. 2010. 84 p. Available at: <https://www.plk-sa.pl/dla-klientow-i-kontrahentow/akty-prawne-i-przepisy/standardy-techniczne>. [In Polish: *Technical Standards: detailed technical conditions for the modernization or construction of railway lines up to a speed $V_{max} \leq 200$ km/h (...) / 250km/h (...)*].
15. Mannhardt, F. & Landmark, A.D. Mining railway traffic control logs. *Transportation Research Procedia*. 2019. 37. P. 227-234. Available at: [http://dx.DOI.org/10.1016/j.trpro.2018.12.187](http://dx.doi.org/10.1016/j.trpro.2018.12.187).
16. Bai, Yong & Burkett W.R. Rapid bridge replacement: processes, techniques and needs for Improvements. *Journal of Construction Engineering and Management*. ASCE. 2006. Vol. 132. No. 11. November 1. P. 1139-1147. DOI: 10.1061/ASCE0733-93642006132:111139.
17. Burkett, W.R. & Nash, P.T. & Bai, Y. & Hays, C. & Jones, C. Rapid bridge replacement techniques. *Center for Multidisciplinary Research in Transportation*. Texas Department of Transportation. Report No. 0-4568-1. 2004. 212 p. Available at: <https://www.depts.ttu.edu> › complete_reports › 4568-1Rapid_Bridge.
18. Railway Guideline. *Deliverable 3.4: Guideline for replacement of elderly rail infrastructure. Maintenance, renewal and Improvement of rail transport infrastructure to reduce Economic and environmental impacts* (Project co-funded by the European Commission within the 7th Framework Programme - several European countries participated). ARTTIC. 2014. 121 p. (link: [mainline-project.eu](http://www.mainline-project.eu) › IMG › pdf › ml-d3.4-guideline).
19. ID-16. *Instrukcja utrzymania kolejowych obiektów inżynierskich na liniach kolejowych o prędkości do 200/250 km/h. ID-16*. Warszawa. 2014. 153 p. Available at: https://www.researchgate.net/publication/275957867_INSTRUKCJA_utrzymania_kolejowych. [In Polish: *Instructions for maintenance of railway engineering objects on railway lines with speeds up to 200/250 km/h. ID-16*].
20. Bętkowski, P. Koncepcje przebudowy wiaduktu kolejowego poddanego wpływowi eksploatacji górniczej. *Archiwum Instytutu Inżynierii Lądowej*. 2009. No. 5. P. 51-62. Available at: www.researchgate.net/publication/307466898_Koncepcje_przebudowy_wiaduktu. [In Polish: *Conceptions rebuilding railway viaduct under influence of coal mining*].
21. Salunkhe, D.P. & Chvan, G. & Bartakke R.N. & R Kothavale P.R. An Overview on Methods for Slope Stability Analysis. *International Journal of Engineering Research and Technology*. 2017. Vol. 6. No. 03. P. 528-535. DOI: 10.17577/IJERTV6IS030496.
22. Bogusz, W. & Godlewski, T. Geotechnical design of railway embankments – requirements and challenges. *MATEC Web of Conferences*. 2019. Vol. 262(11002). P. 1-8. Available at: <https://doi.org/10.1051/mateconf/201926211002>.
23. Likitlersuang, S. & Pholkainuwatra, P. & Chompoorat, T. & Keawsawasvong, K. Numerical Modelling of Railway Embankments for High-Speed Train Constructed on Soft Soil. *Journal of GeoEngineering*. 2018. Vol. 13. No. 3. P. 149-159. Available at: [http://dx.doi.org/10.6310/jog.201809_13\(3\).6](http://dx.doi.org/10.6310/jog.201809_13(3).6).
24. Chun-Ming, XU. Study on temporary support of continuous girder bridge in construction. *World Construction*. 2017. Vol. 6. No. 1. P. 8-13. Available at: www.researchgate.net/publication/316639751_Study_on_temporary_support_of_continuous.