

**Keywords:** hardware and software package; VTOL airplane; unmanned aerial vehicle

**Sergii FIRSOV, Igor KULIK\***

National Aerospace University “Kharkiv Aviation Institute”

Chkalova str. 17, Kharkiv, 61070, Ukraine

\**Corresponding author.* E-mail: [phitochai@gmail.com](mailto:phitochai@gmail.com)

## COMPACT VERTICAL TAKE-OFF AND LANDING AERIAL VEHICLE FOR MONITORING TASKS IN DENSE URBAN AREAS

**Summary.** Using of aerial vehicles with onboard sensory and broadcasting apparatus for monitoring a variety of objects and processes in inaccessible places of the city. A hardware and software package for the task solving is proposed in the article. Presented vehicle is a vertical take-off and landing airplane of tail-sitter type.

## МАЛОГАБАРИТНЫЙ ЛЕТАТЕЛЬНЫЙ АППАРАТ ВЕРТИКАЛЬНОГО ВЗЛЕТА И ПОСАДКИ ДЛЯ ЗАДАЧ МОНИТОРИНГА В УСЛОВИЯХ ПЛОТНОЙ ГОРОДСКОЙ ЗАСТРОЙКИ

**Аннотация.** Мониторинг ряда городских объектов и процессов, расположенных в труднодоступных местах, возможен с помощью летательных аппаратов с бортовыми сенсорными и транслирующими средствами. Аппаратный и программный комплекс для решения задачи предложен в этой статье. Представленный аппарат является самолетом вертикального взлета и посадки типа tail-sitter.

### 1. INTRODUCTION

Urbanization process has led to emergence of the problem of life safety in cities. It is destabilized by many factors. Among them is the number of critical factors. Such factors include fires in high-rise buildings, accidents in urban engineering networks, major traffic accidents, massive demonstrations, man-made disasters. Effective monitoring and effective operations of rescue teams are required to localize and neutralize the destabilizing factors. Therefore, the first step in ensuring the safety of life in cities is to organize the monitoring of the most dangerous situations. Dense planning of urban neighborhoods significantly complicates the task of monitoring of the destabilizing factors. Perspective technical means of monitoring is the usage of a micro aerial vehicle (MAV) of tail-sitter type with vertical takeoff and landing (VTOL) options as a flying platform with hardware for monitoring and data transmitting. The effectiveness of such systems is proved by numerous examples of the military vehicles in the last decade [1]. Development of the high-maneuverable MAV, which is achieved due to modes of vertical takeoff and landing, as the basic active element of the monitoring hardware and software complex, is a relevant trend in solving the problem of ensuring safety of life in cities.

## 2. PROBLEM CONDITION AND SOLVING METHODS

Effective monitoring of certain objects and processes in inaccessible places of the city significantly depends on functional capabilities of the MAV with onboard sensors and transmitters. Four main requirements to the MAV that were formulated accordingly to the tasks of monitoring in dense urban areas are described below.

The first requirement is minimal weight and size characteristics of a flying platform. The takeoff mass of the MAV is defined as a sum of platform and payload masses. According to the different evaluations, the payload mass amounts up to 50% of the takeoff mass. Dimensions of the platform have to be minimal for successful infiltration into hardly accessible places. Weight and size characteristics depend on aircraft configuration and also on thrust-to-weight ratio of the MAV. Configuration that satisfies minimal weight and size requirements is formed as a result of the project works.

The second requirement is high maneuverability. It is caused by the necessity for monitoring of fast-paced incidents in dense urban areas. Particularly, the hovering mode is needed to provide a qualitative overlook of target objects. The ability to quickly fly up to place of an emergency, and leave the work area if necessary is also needed.

The third requirement concerns the survivability of the platform in cases of collision with different obstacles, getting into local turbulent air flows during fires and industrial accidents, while operating in extreme conditions.

The fourth requirement is related to restrictions on the cost of the flying platform, operating costs and payback period of the entire complex, including MAV with payload and ground station for receiving and processing information.

Analysis of existing MAV models in accordance with the requirements allowed to identify the following trends of development.

Highly maneuverable MAV “Dragonfly” was designed in the University of Arizona (USA). Similarly is MAV “Mini Vertigo”, designed by students of the same university and based on the principle of D-wing with twin-rotor co-axial propulsion system. Its hovering ability and transition from vertical to horizontal flight mode were demonstrated during the MAV’07 competition, established by the SUPAERO institute [2].

Some of the MAV models with single-rotor propulsion system allows to hover in a vertical position. For example, RC acrobatic planes [3]. Such airplanes have extremely lightweight hull, also equipped with light DC motors and batteries. High thrust-to-weight ratio and a larger area of the control surfaces provide high maneuverability for performing aerobatics.

Design of single-rotor MAV noticeably depends on the number of factors associated with the engine: torque reaction from engine and propeller, corkscrewing effect of the slipstream, gyroscopic action of the propeller, asymmetric loading of the propeller (P-factor).

Torque reaction involves Newton’s Third Law of Physics – for every action, there is an equal and opposite reaction. As applied to the MAV, this means that as the internal engine parts and propeller are revolving in one direction, an equal force is trying to rotate the MAV in the opposite direction. When the MAV is airborne, this force is acting around the longitudinal axis, tending to make the MAV roll. Most engines rotate the propeller clockwise, so the torque reaction causes the MAV to roll counter-clockwise.

The high-speed rotation of an airplane propeller gives a corkscrew or spiraling rotation to the slipstream. At high propeller speeds and low forward speed, this spiraling rotation is very compact and exerts a strong sideward force on the MAV’s vertical tail surface. When this spiraling slipstream strikes the vertical fin on the left, it causes a left yaw turning moment.

The rotating propeller of the MAV makes a significant gyroscope action and has similar properties. Any time a force is applied to deflect the propeller out of its plane of rotation, the resulting force is 90° ahead of and in the direction of rotation and in the direction of application, causing a pitching moment, a yawing moment, or a combination of the two depending upon the point at which the force was applied. As a result of gyroscopic action any yawing around the vertical axis results in a pitching moment, and any pitching around the lateral axis results in a yawing moment.

When an airplane is flying with a high angle of attack, the “bite” of the downward moving blade is greater than the “bite” of the upward moving blade; thus moving the center of thrust to the right of the prop disc area – causing a yawing moment toward the left around the vertical axis. Simply stated, when the airplane is flying at a high angle of attack, the downward moving blade has a higher resultant velocity; therefore creating more lift than the upward moving blade. This moment reaches its maximum value when the engine gives maximum thrust and the angle of attack is also maximum [4].

To maintain positive control of the airplane in all flight conditions, the pilot (operator) must apply the flight controls as necessary to compensate for these varying moments. But this increases the usage of energy for control process and decreases the control effectiveness. Within the described task, the torque reaction does a lot more affection. In the horizontal flight mode this reaction is insignificant because the lift force made by both wings’ airfoil aligns the MAV in horizontal position. But during the vertical flight there’s no lift produced by the wings, so the only way to decrease the torque reaction for a one-rotor MAV is to use control surfaces. That significantly decreases their effectiveness because most of the control surfaces turning range is used for parrying and there’s a small part of the range left for control tasks.

Twin-rotor co-axial propulsion system involves the installation of two rotors, one after another. The rotors spin in opposite directions, so that the rear rotor drives the rotating slipstream from the front rotor in opposite direction, thereby eliminating the influence of the torque reaction and the corkscrewing effect on the vehicle. Gyroscopic moments of both screws are almost equal and are directed in opposite, thus the summing moment will be slightly small [5].

Thus, the twin-rotor co-axial propulsion system is more preferable for this project dedicated to usage of maneuverable MAV in dense urban areas. The flying platform should independently solve two related tasks. The first task is to provide the requested angular orientation during the flight. The second task is to control the motion of the center of mass accordingly to the flight program. The first task is basic and it leads to development of an automatic control system (ACS) for the MAV. Methods of designing of angular orientation systems are described relative to large-sized aircraft [6]. The speciality of the MAV usage in dense urban areas generates new actual tasks of angular orientation control for vehicle with minimal weight and size in conditions of large perturbing effects caused by turbulence and possible conditions. With such perturbations it is not enough to use the linearized mathematical model, so the synthesis process must be iterative, with usage of experimental data to obtain a satisfactory result. Current study is devoted to the task of synthesis of the automatic orientation system (AOS) for the flying platform in conditions of large disturbances.

### 3. MAV ORIENTATION SYSTEM

The functional of the orientation system consists of the automatic orientation object (AOO) that includes flying platform (FP), sensors (S) and an actuator (A); and also the automatic orientation device (AOD), including microcontroller unit (MCU), a digital-to-analog converter (DAC) and an analog-to-digital converter (ADC). AOO and AOD are connected using the feedback automatic control principle.

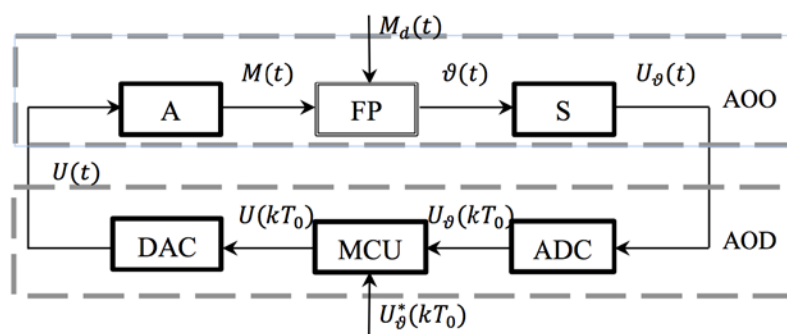

Fig. 1. Functional diagram of MAV angular orientation system for pitch angle

Рис. 1. Функциональная схема системы ориентации МЛА для угла тангажа

A control moment  $M(t)$  and a disturbing moment  $M_d(t)$  act on FP. Its reaction is characterized by the deviation of a pitch angle  $\vartheta(t)$ . The sensor converts the angle  $\vartheta(t)$  into a corresponding change of voltage  $U_\vartheta(t)$ , that is directed to the ADC which converts it into a digital signal  $U(kT_0)$ . MCU calculates the difference signal  $\Delta U(kT_0) = U_\vartheta(kT_0) - U_\vartheta^*(kT_0)$ , where  $U_\vartheta^*(kT_0)$  is the desired orientation angle, which forms a control influence accordingly to the orientation algorithm. This discrete signal is converted to analog  $U(t)$  by DAC unit and it further goes to the actuator that generates the control moment  $M(t)$ , parrying the action of disturbing moment  $M_d(t)$ . Thus, the orientation of MAV pitch angular position is fulfilled in accordance with the desired angular position  $U_\vartheta^*(kT_0)$ .

Discrete transfer functions of described functional elements for algorithm synthesis and structural diagram were formulated for three orientation angles: pitch, roll and yaw. Structural diagram for the pitch angle is presented on fig. 2.

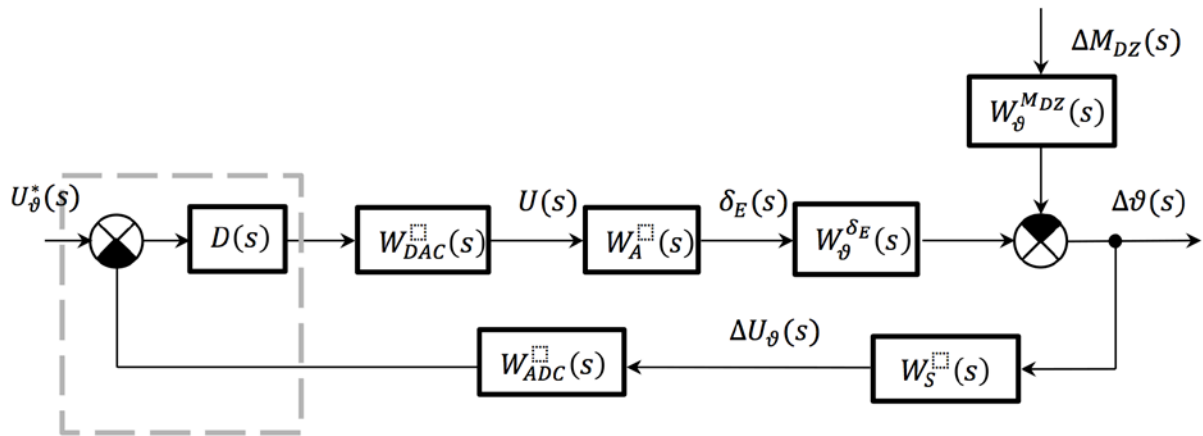

Fig. 2. Structural diagram of MAV angular orientation system for pitch angle  
Рис. 2. Структурная схема системы ориентации МЛА для угла тангажа

#### 4. MAV PROTOTYPE

The prototype was designed to test the construction, the aircraft configuration, the ACS and to discover functional capabilities of the MAV. Prototype vehicle is of a D-wing aircraft configuration. The propulsion system uses two brushless DC motors. Each brushless motor requires an electronic speed controller (ESC). ESC is a specific microcontroller, which forms switch signals for the motor's windings in the specified sequence and frequency. The ESC's output signal depends on its input signal, represented by pulse-width modulated (PWM) impulse with width range from 1000  $\mu\text{s}$  (which corresponds to a complete stop of the motor) to 2000  $\mu\text{s}$  (maximal rotation speed). Servomechanisms are used for turning the control surfaces [7].

The inertial navigation system (INS) consists of a three-axis gyroscope and a three-axis accelerometer based on the microelectronic mechanical system (MEMS) technology. These devices are placed on one chip MPU 6050. Used sensors have certain drawbacks.

MEMS-gyroscope measures the angular velocity of an object, so the data from the sensor must be integrated to calculate the angular position. One of the simplest and easiest integration methods is rectangles method. More accurate, but extremely resource-intensive approaches, such as the Runge-Kutta method are used in computer simulations of different physical processes. In the context of current task, the high-speed performance is critical, so it was decided to use the simple rectangles method.

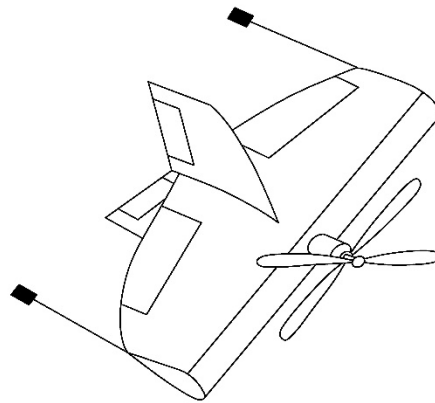

Fig. 3. MAV prototype appearance

Рис. 3. Внешний вид прототипа МЛА

To compute orientation from the MEMS-accelerometer, we rely on the fact that there is a constant gravitational pull of 1g downwards. If no additional forces are acting on the accelerometer the magnitude of the acceleration detected will always measure 1g, and the sensor's rotation can be computed from the apparent position of the acceleration vector. It is important to note that the accelerometer results provide accurate orientation angles as long as gravity is the only force acting on the sensor. The net result is that accelerometer data tends to be very noisy, with brief but significant perturbations. If these can be averaged out, the accelerometer provides accurate results over timescales longer than the perturbations [8].

Both of sensors have their own systematic faults: accelerometer is highly responsive to external perturbations, accuracy of the calculated gyroscope data is significantly reduced by errors of integration and zero drift. A complementary filter allows to combine the data from both sensors and compensate the deviations. Work of this filter is defined by the formula:

$$a = (1 - K) \cdot gyr + K \cdot acc, \quad (1)$$

where:  $a$  — filtered, resulting angle value;  $gyr$  и  $acc$  – values of angle, measured by gyroscope and accelerometer,  $K$  – complementary filter coefficient.

The resulting value represents the sum of the integrated value from gyroscope and the instantaneous value from accelerometer. In fact, the main function of the filter in this case is to offset the zero drift and gyro error discrete integration. At each integration step the integral value of the angular position from the gyroscope is being corrected using the accelerometer value. The rate of correction is determined by the complementary filter coefficient  $K$ .

Selection of this coefficient depends on the zero drift magnitude, the rate of calculation error accumulation and the conditions of the vehicle usage. So, too big value of  $K$  will cause strong response to hull and motor vibrations. Too small value of  $K$  may be insufficient to eliminate the zero drift of the gyroscope. Typically, the complementary filter coefficient is selected manually for each INS on the basis of the above conditions. Selection was made empirically using the sources and the results of experiments. Adopted  $K = 0.96$ .

## 5. CONCLUSIONS

The study proved the possibility of MAV research for monitoring in dense urban areas. These are four basic requirements for a flying platform. The necessity of promoting of rational aerodynamic configurations of MAV with twin-rotor co-axial propulsion system was identified during the analysis of condition of the MAV development. The automatic orientation system, that satisfies formulated

requirements are also needed. The study represents different models of angular orientation system. The MAV prototype was constructed and experimental research in automated flight mode are being processed nowadays.

## References

1. Илюшко, В. & Митрохович, М. и др. *Беспилотные летательные аппараты: Методика приближенных расчётов основных параметров и характеристик*. ЦНИИ ВВТ ВС Украины. 2009. [In Russian: Pyushko, V. & Mitrochovitch, M. and others. *Unmanned aerial vehicles: Methods of approximate calculations of main parameters and characteristics*. TsNII VVT VS of Ukraine. 2009].
2. *7th European Micro Air Conference and Flight competition*. Available at: <http://aeromav.free.fr/MAV07/index.html>.
3. Shkaraev, S. Aerodynamic Design of VTOL Micro Air Vehicles. Proceeding of 3rd US-European Competition and Workshop on Micro Air Vehicle Systems (MAV07) & European Micro Air Vehicle Conference and Flight Competition (EMAV2007). 2007.
4. *Principles of flight*. Oxford Aviation Academy. 2009.
5. *Соосные воздушные винты*. Бюро новой техники НКАП. 1944. [In Russian: *Coaxial airscrews*. New technical NCAP bureau. 1944].
6. Боднер В. *Системы управления летательными аппаратами*. «Машиностроение». 1973. [In Russian: Bodner V. *Aircraft control systems*. “Mashinostroenie”. 1973].
7. Firsov, S., Plavynska, N., Rudenko, K. Hardware and software package for search, detection and first aid means delivery in rough terrain on basis of a three rotor unmanned aerial vehicle. In: *II International Symposium of Young Researchers “Transport Problems”*. Katowice, Poland. 2013.
8. *Gyroscopes and Accelerometers on a Chip*. Available at: <http://www.geekmomprojects.com/gyroscopes-and-accelerometers-on-a-chip/>.

Received 12.03.2014; accepted in revised form 11.08.2015