

Keywords: mining facility; open-mine transport; trunk transport; automotive barrow; robotic automation; trailer conveyor; remote sensing system; generality

Anatoly KOLGA*, **Alexander RAKHMANGULOV**, **Nikita OSINTSEV**

Nosov Magnitogorsk State Technical University
Lenina av., 38, 455000, Magnitogorsk, Russia

Aleksander ŚLADKOWSKI

Silesian University of Technology, Faculty of Transport
Krasinski st. 8, 40-019 Katowice, Poland

Ivan STOLPOVSKIKH

Kazakh National Technical University named after K.I. Satpaev
Satpaev st. 22, 050013 Almaty, Kazakhstan

*Corresponding author. E-mail: kad-55@magtu.ru

ROBOTIC TRANSPORT COMPLEX OF AUTOMOTIVE VEHICLES FOR HANDLING OF ROCK MASS AT THE PROCESS OF OPEN CAST MINING

Summary. The article is concerned with the applicability of the robotic transportation complex of automotive barrows for haulage transportation along various transport routes of mining enterprises. The simultaneous application of robotic transport and telemetry links makes the door-to-door transportation possible, i.e. direct transportation from the starting to the final point avoiding intermediate storage and a considerable part of auxiliary equipment.

РОБОТИЗИРОВАННЫЙ ТРАНСПОРТНЫЙ КОМПЛЕКС САМОХОДНЫХ МАШИН ДЛЯ ПЕРЕМЕЩЕНИЯ ГОРНОЙ МАССЫ ПРИ ОТКРЫТОЙ РАЗРАБОТКЕ МЕСТОРОЖДЕНИЙ

Аннотация. В статье рассмотрена возможность применения роботизированного транспортного комплекса (РТК) самоходных машин для перемещения грузов на различных маршрутах горных предприятий. Совместное использование роботизированного транспорта и телеметрических связей позволяет осуществлять бесперегрузочную транспортировку от начального до конечного пунктов, исключая промежуточные складирования и значительную часть дополнительного оборудования.

1. INTRODUCTION

For many countries mining is the basis of industrial capacity, which determines the economic performance of other industries. Further development of the mining industry will result in the increase of the level of mining, which will make it necessary to improve the facilities already in operation and to introduce new production facilities. The re-equipment of mining enterprises is connected with further development and improvement of transportation facilities [1]. The efficiency of the transportation process determines the production and economic performance of mining as a whole as the transportation costs make up more than a half of the total costs of mineral mining operations. Transportation has reached a new quality level recently by introducing automatic and robotic transport

complexes. Thus the role of a man has also changed and his main function now is to maintain the transport facilities and provide their smooth operation in the design mode, which means failure-free and continuous operation [2].

All transportation vehicles are divided into two main groups: transportation vehicles operating in cycles and continuous vehicles. At present automobile transport is the most common cyclic transport at mining companies, while conveyors are the most common continuous machines. Each mode of transport has its advantages and disadvantages, which determine its field of application.

The main advantage of automobile transport is its mobility. Only automobile transport can deliver the freight to the point of use without transshipment and along any course of movement. So despite all the drawbacks such as high cost of fuel and lubricants, maintenance, the truck itself, etc., this advantage determines the wide application of automobile transport in all sectors of national economy. However, the main disadvantage of automobile transport, which is typical for all transportation vehicles operating in cycles, is its repeating pattern. Efficiency of transportation vehicles operating in cycles depends on the load-carrying capacity and the transportation distance and the longer this distance, the lower the efficiency. Maximum efficiency of automobile transport application is achieved when the transportation distance is up to 3 km. If the transportation distance exceeds 7 km, application of automobile transport is no longer cost-effective. To improve the efficiency of automobile transport application at distances exceeding 3 km the designers of open-pit dump trucks tend to increase their load-carrying capacity. Open-pit dump trucks with load-carrying capacity of 450 t are already in operation and 500 t open-pit dump trucks are being tested. Further increase of open-pit dump trucks load-carrying capacity is limited by the lack of tires capable of withstanding heavy loads.

It should be noted that the increase of open-pit dump truck load-carrying capacity in its turn requires larger volume of development operations and other mining equipment of special design (excavators, boring machines, etc.) as well as communication lines matching the load-carrying capacity of automobile transport [3].

Unlike the automobile transport, conveyors do not have that disadvantage as they belong to continuous machines. Efficiency of continuous machines does not depend on the transportation distance [4].

The main disadvantage of modern conveyors is the lack of mobility. Conveyors are capable of transporting loads only along certain permanent route determined by the pulling equipment [5].

From the customer point of view, the ideal means of transportation could be the transport combining the advantage of automobile transport (mobility) and the advantage of conveyor transport (continuous operation) [6].

2. FEASIBLE SOLUTION

One of the possible solutions to the problem could be the combination of automotive robot-aided machines into a unified transport complex by means of telemetry.

To understand the way it works it is necessary to consider the operating principle of the trailer load-carrying conveyor. The trailer load-carrying conveyor is a flexible pulling unit (as a rule, it is a chain) moving along the strictly defined closed route. Pusher mechanisms of load carriers are attached to the pulling unit at appropriate intervals. The pulling unit with the drive is the main element of the conveyor and it fulfills three main functions: to transfer the propelling force; travel direction and to provide steady motion of load carriers. The main advantages of such conveyors are simple design, low energy consumption and continuous transportation process. At the same time the movement of load carriers along the strictly defined routes deprives the conveyor of mobility.

If we eliminate the pulling unit from the system of the load-carrying conveyor and distribute its functions between the new conveyor elements such as individual barrow drive; slave programmable logic controller (PLC) and telemetry, we can get a robotic transportation complex of automotive barrows as a result. In such a transportation complex all barrows have the mobility of automobile transport and, at the same time, telemetry provides the necessary movement steadiness characteristic for load carriers of the usual conveyor.

Some specialists argue that this technical solution results in higher energy consumption of the transportation process and high cost of intelligent control system.

Indeed the total drive power of 40 automotive barrows with the load-bearing capacity of 1 ton each is higher than the power of the open-pit dump truck engine with the load-bearing capacity of 40 tons. But it should be taken into account that this technical solution makes it possible to do without a human operator in the transportation process and to eliminate the possibility of interruptions in the transportation process in case of failure of one or several barrows as well as interruptions for lunch breaks, maintenance and repair. So the production capacity of the complex of 40 automotive barrows will be higher than the production capacity of an open-pit dump truck with the load-bearing capacity of 40 tons. Besides the expenditures on the increase of the volume of development operations in the process of transportation lanes preparation as well as expenditures on the purchase of more powerful equipment for operation with open-pit dump trucks with high load-bearing capacity make automobile transport of high load-bearing capacity less economically sound.

In Fig. 1 one can see a typical scheme of an opencast mine with two transportation sections, which can be replaced with a robotic transportation complex of automotive barrows: I-the section of line-haul (railway) transport; II-the section of open-cut (automobile) transport.

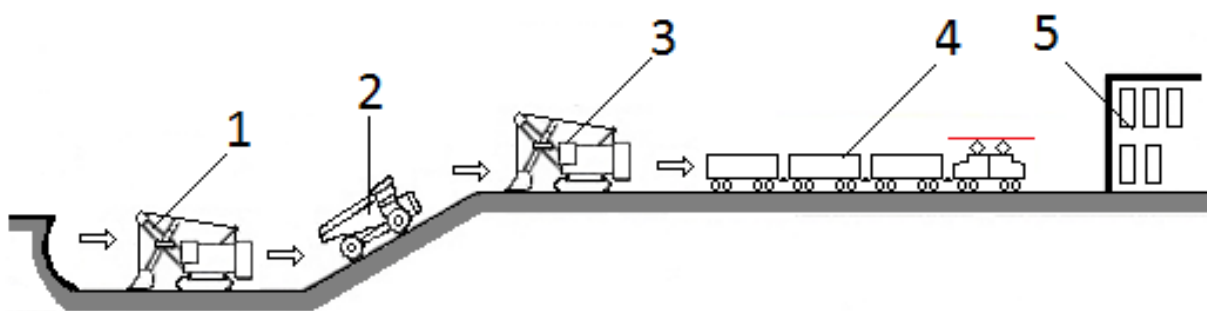

Fig. 1. Typical scheme of mined rock transportation: 1 - excavation, 2 - open-cut transport (automobile), 3 - transshipment on ore stockpile, 4 - railway transport, 5 - processing factory

Рис. 1. Типовая схема транспортирования горной массы: 1 - экскавация в забое, 2 - автомобильный транспорт, 3 - перегрузка на рудном складе, 4 - железнодорожный транспорт, 5 - перерабатывающая фабрика

Unlike current trailer load carrying conveyors, each automotive barrow of the robotic transportation complex can move along its own individual path and has its own individual automotive unit and its own individual motion control system. To provide continuous motion of barrows, telemetry is used as a connection link (instead of the pulling chain) and this link makes it possible for the barrows to be independent and at the same time to operate in a team as a single machine using a control program. Moreover the motion path can be changed even in the course of movement.

The automotive robotic transportation complex is made up of separate elements 5 (Fig. 2) equipped with programmable microcontrollers, these elements have telemetry control from the common computerized terminal *I* connected with the controller 2 transmitting radio (navigation) signals 3, 4.

Depending on the operating conditions of the complex different data transmission systems can be used to transfer the signals (Wi-Fi, WiMAX, MESH, RFID, Bluetooth, ZigBee and others). Application of satellite systems makes distant control and monitoring of the process possible [7, 8].

The mechanical design of the conveyor automotive barrows consists of the chassis on pneumatic-tire wheels with the turning gear, braking system and the individual automotive unit. Depending on the work to be done, the automotive barrows can be equipped with different easily detachable load-carrying surfaces (side-extended body, decking, tank, shelves, etc.) [9].

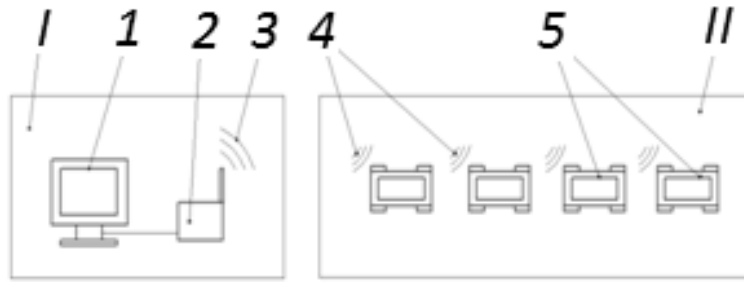

Fig. 2. Control principle of the robotic transportation complex: *I* - separate operator workstation; *II* - active led of the robotic transportation complex; 1 - host computer; 2 - controller transmitting signals; 3 - outgoing signals; 4 - incoming signals; 5 - automotive barrows

Рис. 2. Принцип управление РТК: *I* - изолированное рабочее место оператора; *II* - участок работы РТК; 1 - центральный компьютер; 2 - контролер передающий сигналы; 3 - исходящие сигналы; 4 - входящие сигналы; 5 - самоходные тележки

The control system of the conveyor automotive barrows consists of a microcontroller transmitting control signals to the chassis, the turning gear and the braking system (Fig. 3).

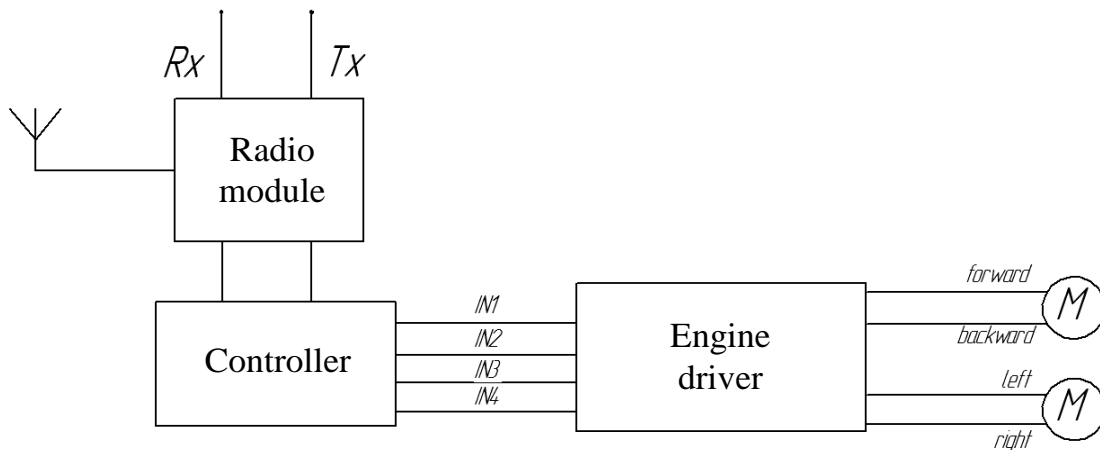

Fig. 3. Scheme of signal transmission to the barrow chassis

Рис. 3. Схема передачи сигнала на шасси тележки

The traffic diagram of the automotive robotic transportation complex is given in Fig. 4. Automotive barrows carry cargo repeating rhythmical time-consistent operations.

The empty automotive barrows 1 can be used to transport tools, auxiliary materials, etc.

The required amount of automotive barrows can at any time be taken out of the transportation process for repair, maintenance or for associated transportation. This process does not require any halts of the transportation and all the automotive barrows 3 used for supplementary operations will not hinder the major transportation process.

As the automotive barrows are independent and linked with each other only through telemetric links, the performance control of the robotic transportation complex can be carried out both by means of the travel speed variation and by changing the number of automotive barrows operating along the route.

3. EXPERIMENTAL ASSEMBLY

A test bench (Fig. 5) was developed to test the productive capacity of the robotic transportation complex. The following equipment was used to manufacture the test bench: an automatic circuit breaker ABB 2A, power supply Mean Well DR-4524, a 4V power supply, carrier sockets for the relay R4, a relay switch Relpol R4 24V, PLC SMH 2010.

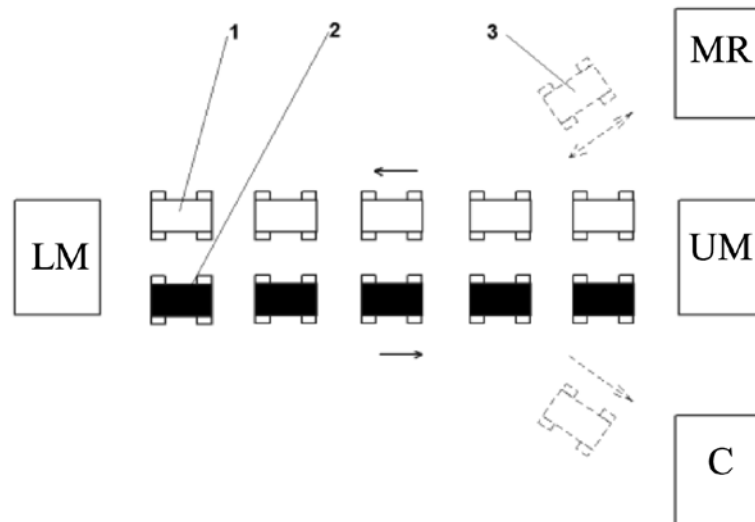

Fig. 4. Traffic diagram of the robotic barrow complex: LM - loading mechanism; UM - unloading machine; MR - maintenance and repair space; C - the object, for which transportation is needed; 1 - empty barrow; 2 - loaded barrow; 3 - the barrow moving to the maintenance space

Рис. 4. Схема движения роботизированного тележечного комплекса: LM - загрузочное устройство; UM - разгрузочное устройство; MR - место для технического обслуживания и ремонта; C - сторонний объект, для которого необходима транспортировка; 1 - порожняя тележка; 2 - груженная тележка; 3 - тележка направляющая на техническое обслуживание

Chassis of radio-controlled models were used as the chassis of the automotive barrows (Fig. 5).

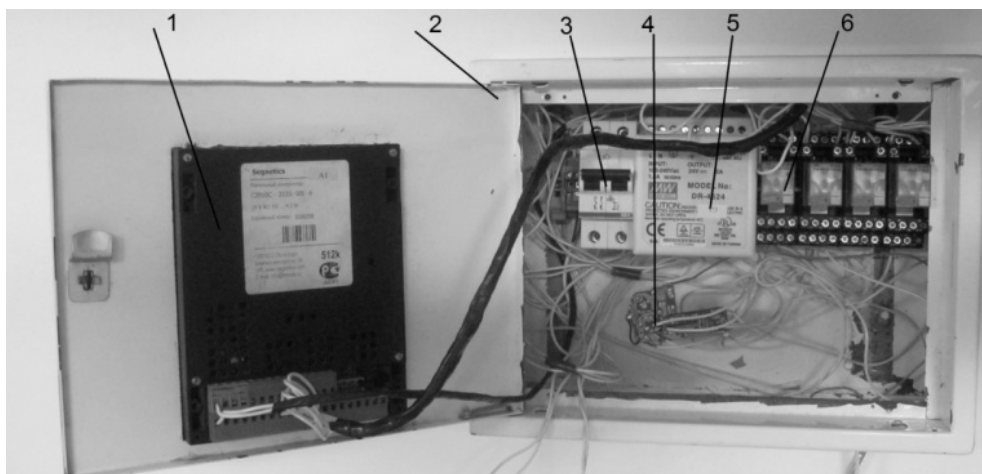

Fig. 5. Control module: 1 - controller; 2 - housing; 3 - automatic circuit breaker; 4 - radio transmitter; 5 - control module; 6 - relay switch

Рис. 5. Блок управления: 1 - контроллер; 2 - корпус; 3 - автоматический выключатель; 4 - радиопередатчик; 5 - блок управления; 6 - реле

The controller located on the barrow chassis receives signals from the control module and passes them on to the power unit and the turning gear.

The automotive barrow can move in a straight line both forward and backward and it can turn in both directions.

The programmable controller SMH 2010 was chosen as the control system. This controller is shown in figure 6. SMH 2010 is a compact fast programmable controller designed for control operations requiring up to 832 inputs/outputs. Panel version of the controller makes it possible to use it also as the operator's panel installed outside the electric equipment cabinets in the corresponding holes.

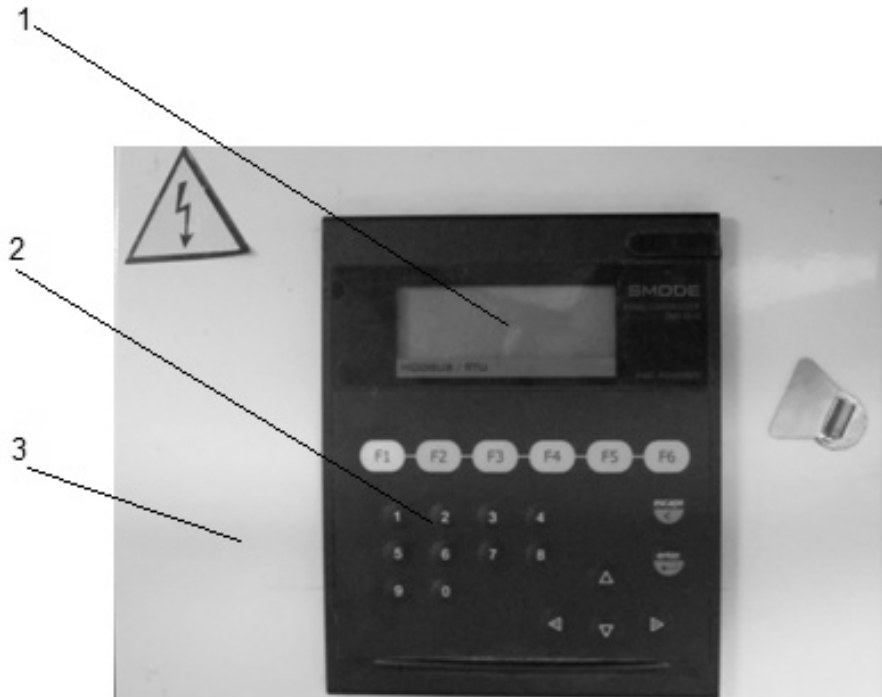

Fig. 6. Controller SMH 2010: 1 - display; 2 - control board; 3 - enclosure

Рис. 6. Контролер SMH 2010: 1 - дисплей; 2 - панель управления; 3 - защитный корпус

The software core of the controller using special development package SMLogix for the OS of MS Windows makes it possible to develop the user control programs for the controller in the language of functional block diagram (FBD).

The basic diagram of the control module is given in Fig. 7.

The test bench makes it possible to simulate the transportation process for various variables (transportation distance, linear load determined by the number of automotive barrows in the complex, route inclination, etc.).

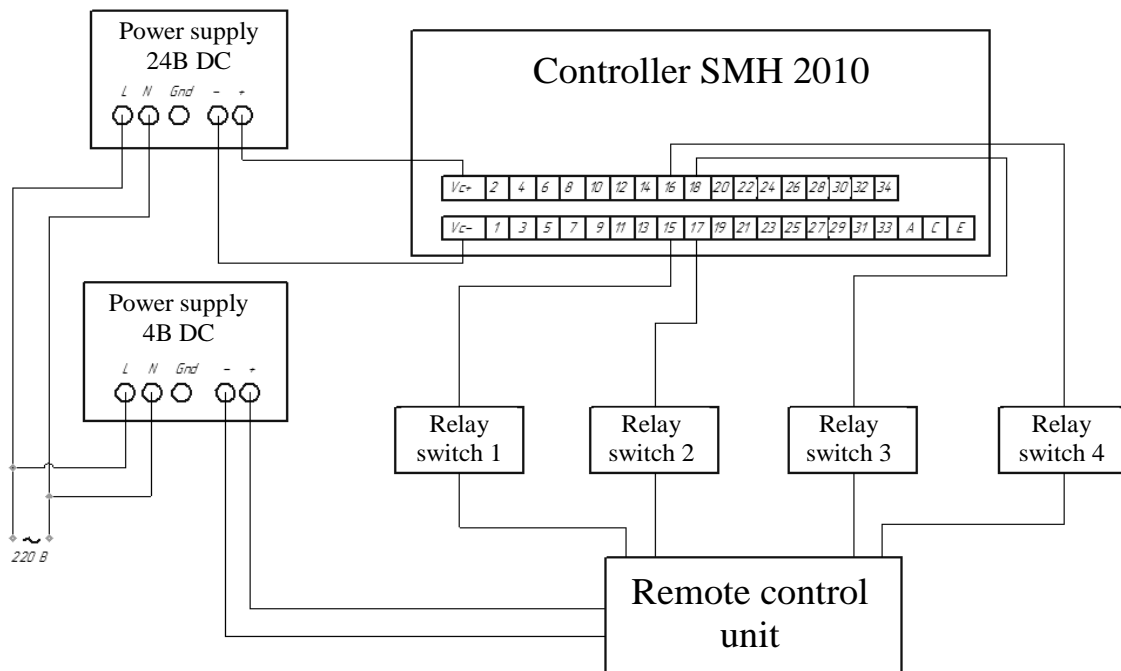

Fig. 7. Basic diagram of the control module

Рис. 7. Принципиальная схема блока управления

4. CONCLUSION

Small overall size of the automotive barrows and the independent drive provide better mobility and the possibility of moving along three dimensionally curved trajectories.

The replacement of locomotive and automobile transport for the robotic transportation complex will make it possible to:

- do without transshipment nodes, intermediate storage and extra auxiliary equipment;
- save the costs of haulage tracks building;
- cut down the size of the operating floors.

Besides, the application of the robotic transportation complex will allow the companies to:

- carry out associated and additional transportation work of handling auxiliary loads, materials, tools, etc.;

- use automotive barrows both as a part of the conveyor complex and as a separate means of transport;

- remotely control and monitor the transportation process;
- maintain and repair the rolling stock without interruption of the transportation process;
- simplify the process of capacity control.

At present high energy requirement of the transportation process and the high cost of the intelligent control system are the main limiting factors of the robotic transportation complex implementation.

However the technological development and application of new technology will allow the developed complex to compete with modern means of transport.

References

1. Подэрни, Р.Ю. *Механическое оборудование карьеров*. Москва: МГГУ. 2003. [In Russian: Poderni, R.Yu. *Mechanical equipment of open cast mines*. Moscow: MGGU, 2003].
2. Hurmuzlu, Y. & Nwokah, O.D.I. *Mechanical Systems Design Handbook: Modeling, Measurement and Control*. CRC Press. 2001.
3. Кольга, А.Д. & Столповских, И.Н. & Меченко, Н.П. Повышение эффективности движения колесных транспортно-технологических машин, используемых при разработке месторождений полезных ископаемых. *Горный журнал Казахстана*. 2014. №1. С. 40-43. [In Russian: Kolga, A.D. & Stolpovskikh, I.N. & Mеченко, N.P. Improvement Movement Efficiency for Wheeled Transportation and Production Machines Used in Exploitation of Mineral Deposits. *Kazakhstan Mining Journal*. 2014. No. 1. P. 40-43].
4. Зенков, Р.Л. & Ивашков, И.И. & Колобов, Л.Н. *Машины непрерывного транспорта*. 2-е изд., перераб. и доп. Москва: Машиностроение. 1987. [In Russian: Zenkov, R.L. & Ivashkov, I.I. & Kolobov, L.N. *Continuous transport machines*. Issue 2, revised and enlarged edition. Moscow: Machine-building. 1987].
5. American Chain Association. *Standard Handbook of Chains: Chains for Power Transmission and Material Handling*. Second Edition. CRC Press. 2005.
6. Галкин, В.И. & Дмитриев, В.Г. & Дьяченко, В.П. и др. Современная теория ленточных конвейеров горных предприятий. Москва. МГГУ. 2005 [In Russian: Galkin, V.I. & Dmitriev, V.G. & Dyachenko, V.P. at al. Modern theory of belt conveyors for mining companies. Moscow. MGGU. 2005].
7. Golka, K. & Bolliger, G. & Vasili, C. *Belt conveyors: principles for calculation and design*. Lugarno, N.S.W. 2007.
8. Rakhmangulov, A. & Kolga, A. & Osintsev, N. & Stolpovskikh, I. & Śladkowski, A. Mathematical model of optimal empty rail car distribution at railway transport nodes. *Transport Problems*. 2014. Vol. 9. No. 3. P. 125-132.
9. McGuire, P.M. *Conveyors: Application, Selection, and Integration*. CRC Press. 2010.

Received 17.05.2013; accepted in revised form 21.05.2015