

base station; rover; antenna; transport unit; turning radius  
slip angle; controllability; road holding

**Anatoliy KULIK\***, **Kostiantyn DERGACHOV**, **Tetiana LYTVYENENKO**

National Aerospace University “Kharkiv Aviation Institute”

Chkalova str. 17, Kharkiv, 61070, Ukraine

\*Corresponding author. E-mail: [anatoly.kulik@gmail.com](mailto:anatoly.kulik@gmail.com)

## THE METHODS FOR DIAGNOSTIC OF THE TECHNICAL CONDITION OF VEHICLES EMPLOYING HIGH PRECISE SATELLITE DATA

**Summary.** The paper presents a methodology for diagnostic of the technical condition of vehicle. The high accuracy of the actual trajectory of the transport aggregate (TA) is provided by the use of local differential mode of global navigation satellite system (GNSS). Comparing the real and rational trajectories will determine the kinematic and dynamic characteristics of the car.

## МЕТОДИКА ИСПОЛЬЗОВАНИЯ ВЫСОКОТОЧНЫХ СПУТНИКОВЫХ ИЗМЕРЕНИЙ ДЛЯ ДИАГНОСТИКИ ТЕХНИЧЕСКОГО СОСТОЯНИЯ ТРАНСПОРТНЫХ СРЕДСТВ

**Аннотация.** Предложена методика определения технического состояния транспортного средства. Высокая точность определения реальной траектории движения транспортного агрегата (ТА) обеспечивается использованием локального дифференциального режима работы GNSS. Сравнение реальной и рациональной траекторий движения позволит определить кинематические и динамические качества автомобиля.

### 1. INTRODUCTION

Great progress in the field of high-precision satellite measurements caused by using dual-frequency measuring instruments and new methods of measurements data analysis allow us to create new technologies that can be applied in various fields of science and technology [3, 6].

One of the most important tasks facing designers, manufacturers and exploiters of vehicles is providing active safety. Along with other factors, which provide safety, in particular importance is placed on achieving the required level of safety and comfort in the design and technical diagnostics of vehicles before their operation.

For today the most comprehensive information for these tasks can be obtained from the test directly using the object or its components. The process of testing is associated with a lot of time and costs using specific computer systems.

We propose to use measurement system for diagnostic of the technical conditions. This complex includes addition to computer instruments for high precision satellite measurements that during the test should be placed directly on the case of the vehicle and record the movement of the calculated points of transport aggregate (TA).

The measured data are compared with data obtained in the simulation or specified technical characteristics of TA. Decision on the technical condition of TA is made based on the analysis. This approach is possible both in the study of dynamic and kinematic qualities of the car.

## 2. GENERAL DESCRIPTION OF PROBLEMS AND METHODS OF THEIR SOLVING

The use of high-precision satellite measurements will make the process of testing available for use on non-equipped test sites, during the operating vehicles or their transportation for delivery to the customer, before serving as a diagnostic tool for service stations. However, the use of such means involves a number of features, which should be identified before testing. First of all, methodology of research and testing should be defined. For the formation of this methodology is necessary to develop the following aspects:

- selecting the object for testing and its mathematical models (MM);
  - selecting coordinate system where measurement will be performed;
  - determination of kinematic or dynamic properties that will be researched during the tests;
  - definition of the functional relationships between the measured parameters, dynamic (kinematic) properties and TA units (mechanisms) providing realization of these properties;
  - definition of test plan and result processing;
  - forming recommendations for further use of the TA.
- Systemic use of these components provides a methodology of testing.

## 3. AIM, TASKS, STRUCTURE AND SELECTING WAYS OF PROBLEM SOLUTION

Methodology of diagnostics the technical state can be shown as a diagram in Fig. 1.

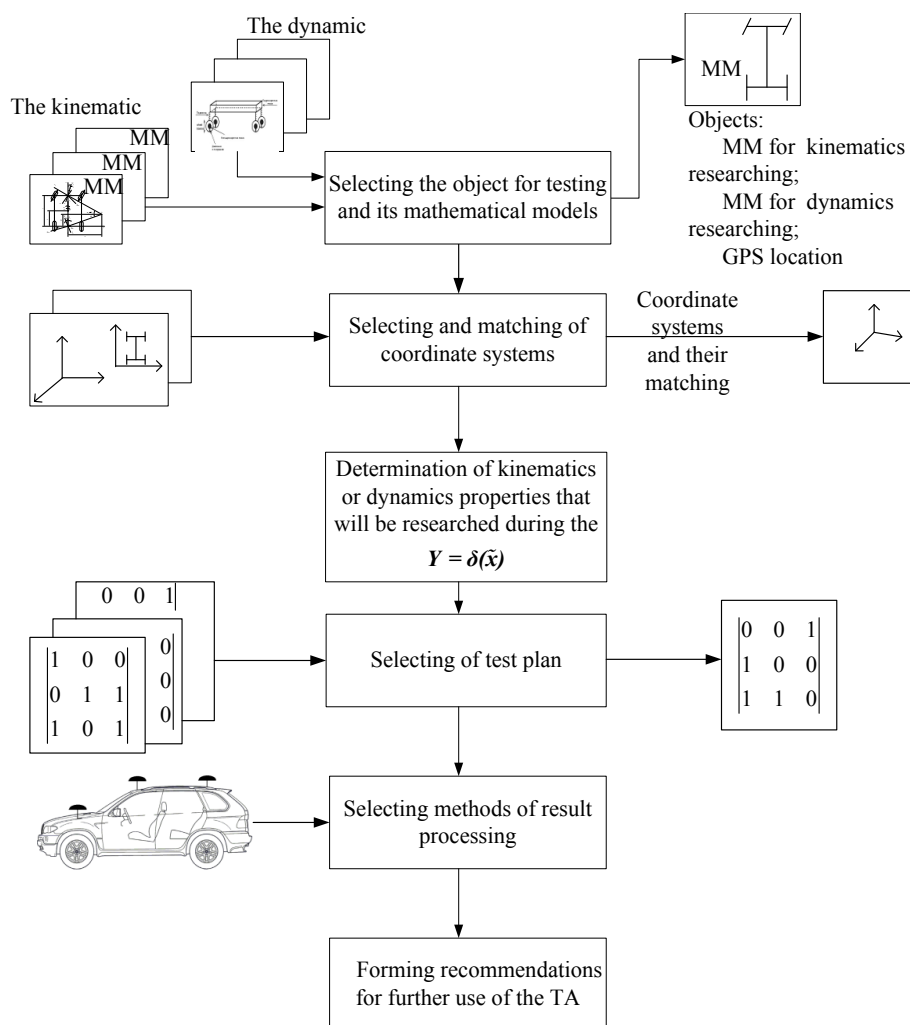

Fig. 1. Methodology of diagnostics of the technical state of automobile  
 Рис. 1. Методика диагностирования технического состояния автомобиля

The concept of building a system for the diagram shown in Fig. 2, has the following fundamental characteristics.

The basic component of the system is the car, the technical condition that is to be evaluated. To do this, it is set a rover receiver and antenna. This receiver is connected to the base station, which is a GPS-receiver, providing the solution to the problem and constitutes the correcting information. Rover receiver considers the amendments to determine its location and the location of the key point of car respectively. Software evaluation device solves problem of comparing the calculated ideal trajectory, and provides information on changing user coordinate for a given period of time.

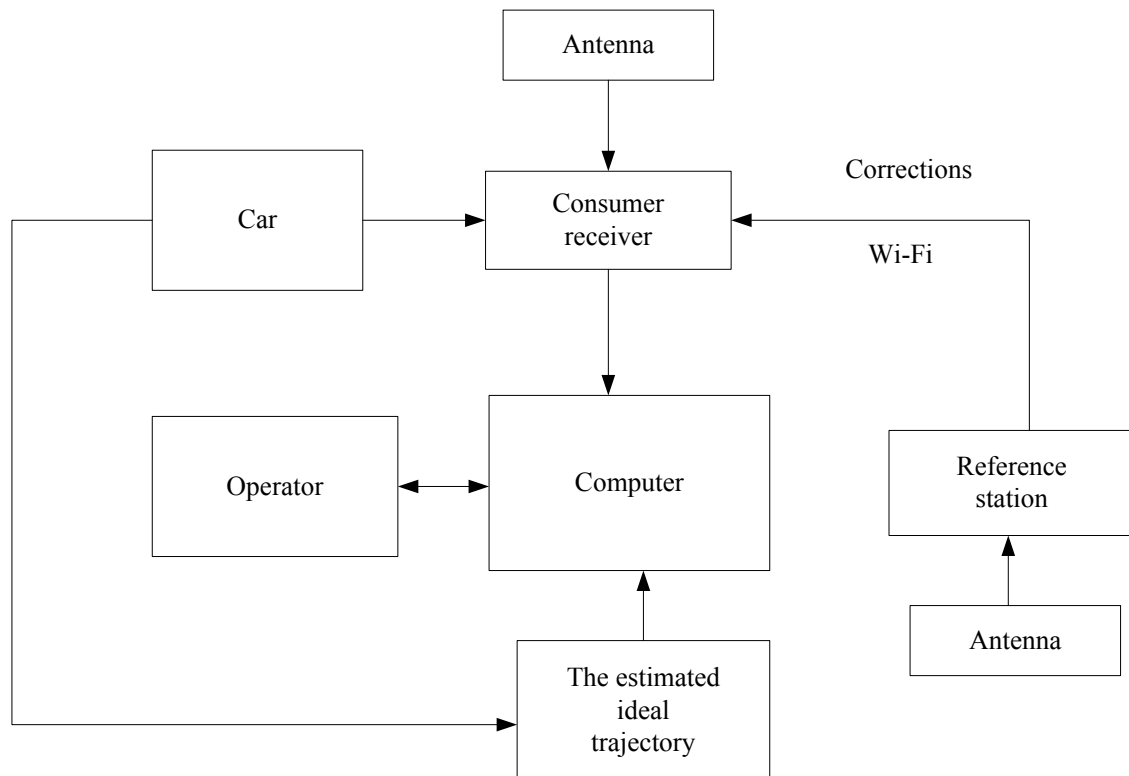

Fig. 2. The diagram of implementing the system of technical diagnostics using DGSS

Рис. 2. Схема реализации системы технической диагностики автомобиля с использованием DGSS

### 3.1. The kinematic mathematical models of testing object

The first step in diagnosis is to select vehicle kinematic and dynamic mathematical models. As the kinematic mathematical model was selected two-axle vehicle with front steered wheels.

Figure 3 shows the design scheme under consideration for two-axle vehicles unsteady turn with the accepted symbols of geometric and kinematic parameters, acting forces and moments. We believe that the weight of the car is concentrated in two locations – the middle of the first and second axis, the motion of which is composed of translational motion around the instantaneous center of rotation and the relative that is expressed angular displacement vectors of linear velocities of these points [1].

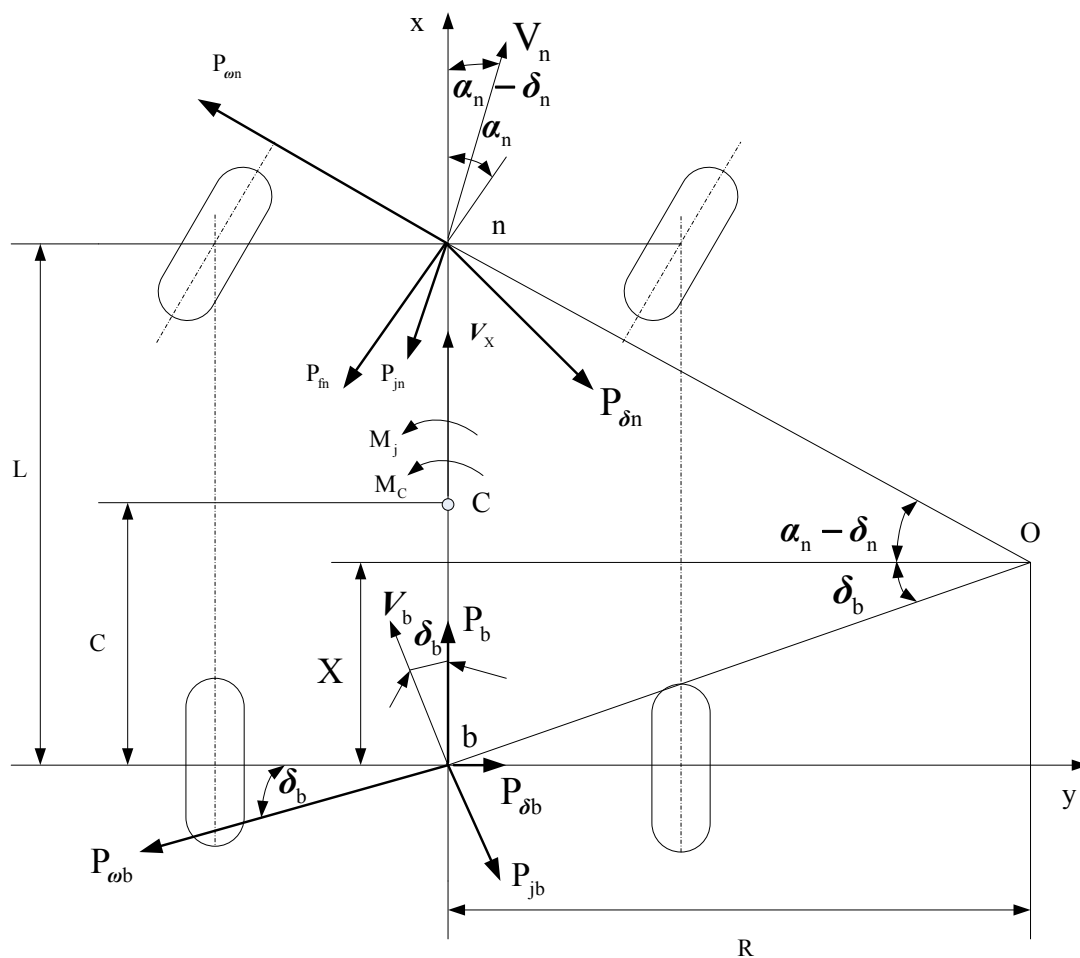

Fig. 3. Diagram of two-axle vehicles with the anterior steered wheels at unsteady rotation

Рис. 3. Расчетная схема двухосной машины с передними управляемыми колесами при неустановившемся повороте

The following parameter are indicated on fig. 3: point C – the center of gravity of the machine, point b – center of the second axis of the unit, point n – center of the first axis of the unit, point O – the instantaneous center of rotation of the unit, c – the distance from the second axis to the center of gravity, L – base of the car, R – instantaneous turning radius, X – projection of the instantaneous center of rotation coordinates on the x-axis absolute coordinate system,  $\alpha_n$  – the angle of the front wheels relative to the longitudinal axis of symmetry of the unit,  $\delta_n, \delta_b$  – slip angles of the first and second axes,  $V_n, V_b$  – velocity vectors of movement of the first and second axes,  $v_x$  – the projection of velocity of the center of gravity of the unit on the axis x,  $P_b$  – pushing force on the drive wheels,  $P_{\delta n}, P_{\delta b}$  – lateral forces of the first and second axes

We obtain the equations reflecting the dependence of the shift the pole of rotation and curvature on the structural and kinematic parameters as:

$$X = \frac{m(L-c)}{LK_{y\delta}} v_x^2 \quad (1)$$

$$K = \frac{aK_{y\delta}}{LK_{y\delta} + mv_x^2 \left(1 - \frac{L-c}{L} \cdot \frac{K_{y\delta} + K_{y\delta}}{K_{y\delta}}\right)}, \quad (2)$$

where  $K$  –curvature of rotation which is equal to:

$$K = \frac{1}{R} \quad (3)$$

### 3.2. The dynamic mathematical models of testing object

This methodology allows us to investigate not only the kinematics, but also the dynamic properties of the vehicle. For example this methodology can be used to estimate the floating action, dynamic loads on the machine during movement and dynamic stability of TA.

When we estimate these parameters disturbing effect is the impact on the profile path in the direction of motion, then calculated the impact of reduced taking into account the action of the pneumatic tire, the suspension of TA which, as the practice shows, is not always accurate. Effects on the body unit is not possible to estimate with sufficient accuracy due to the fact that for today there is no model that describes the interaction of the tire with a profile on the one side and on the other side – there are a large number of random factors such as:

- microprofile road randomness;
- tire pressure;
- tire rate;
- car's rigid suspension;
- coefficient of damping suspension [4].

A typical design diagram for studying the dynamics of the vehicle is shown in Fig. 4.

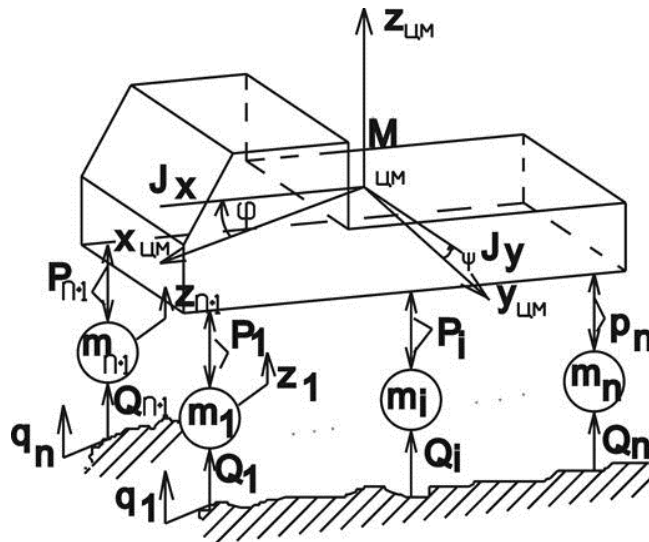

Fig. 4. The typical design diagram for studying the dynamics of the vehicle

Рис. 4. Типичная расчетная схема динамики автомобиля

Thus, setting a measuring device in the measurements channel on the body of the unit, we can increase accuracy by eliminating system error (bus-profile-suspension) on the one side, and on the other side to simplify the model for estimating floating action, evaluation of dynamic loads and stability of the TA.

### 3.3. Selecting and matching of coordinate systems

The formulas (1) and (2) characterize the curvilinear motion of the transport unit in the coordinate system associated with the car. To evaluate the technical condition of the car, we need to know the ideal trajectory in the geocentric coordinate system. To move from one coordinate system to another, we use the direction cosine matrix.

Writing the parameters characterizing the curvilinear motion of TA in projections on the axis associated with TA coordinates system:

$$v = \begin{bmatrix} v_x \\ v_y \\ 0 \end{bmatrix}, \quad R = \begin{bmatrix} 0 \\ R_y \\ 0 \end{bmatrix}, \quad C = \begin{bmatrix} C_x \\ 0 \\ 0 \end{bmatrix}, \quad L = \begin{bmatrix} L_x \\ 0 \\ 0 \end{bmatrix} \quad (4)$$

Using transfer matrix associated with the spherical coordinate system, we obtain the equation, reflecting the dependence of the displacement of the pole and the curvature of the rotation on the structural and kinematic parameters, as follows:

$$X = \frac{m(L-c)}{LK_{y\theta}} v_x^2 (\cos\theta \cdot \cos\varphi + \cos\theta \cdot \sin\varphi - \sin\theta) \quad (5)$$

$$K = \frac{\alpha K_{yn} (\cos\varphi - \sin\varphi)}{LK_{yn} A + m v_x^2 A^2 \left(1 - \frac{L-c}{L} \cdot \frac{K_{yn} + K_{y\theta}}{K_{y\theta}}\right)} \quad (6)$$

$$A = (\cos\theta \cdot \cos\varphi + \cos\theta \cdot \sin\varphi - \sin\theta) \quad (7)$$

Characteristics of curvilinear motion TA obtained from (5) and (6) allow us to construct the ideal trajectory of the transport unit in a spherical coordinate system.

#### 4. EXPERIMENTAL PART

Depending on the kinematic and dynamic properties of the vehicle, which will be explored, it is necessary to form a plan of the experiment.

You must define a point on the car, where the rover receiver will be installed. Since the parameters of the test vehicle are known, the receiver can be installed anywhere on the vehicle, since the coordinates of the remaining points can be calculated.

Necessary to consider that in vehicle monitoring systems installation location GPS antenna is essential both in terms of quality of the system as a whole, and for medical reasons [9,10].

When placing the antenna inside the vehicle, there is deterioration in the quality of reception and decrease the accuracy of the coordinates. Therefore it is necessary to place the antenna outside the vehicle.

The test is the car, the parameters of which the technical specifications with the full weight. Pre sure you check the angles of the steered wheels, the gaps in the steering, tire pressure, tire tread wear, which must not exceed 30% of its original height. Length of sections shall be 500 m at speeds of 10-30 km/h and 1000 m at high speeds [8].

The object of the tests performed VAZ-2103. The main "factory" car specifications are presented in Table 1.

Table 1

## VAZ-2103 car specifications

Parameter	Value
Car body	
Length	4116mm
Width	1611 mm
Height	1440 mm
Wheelbase	2424 mm
Front track	1365 mm
Back track	1321 mm
Ground clearance	170 mm
Operational performance	
Maximum speed	150 km / h
Acceleration time (0-100 km / h)	19 s
Curb vehicle weight	965 kg
Gross vehicle weight	1430 kg
Tire size	175/70 SR13

Location of the antennas is shown in Fig. 5 and Fig. 6

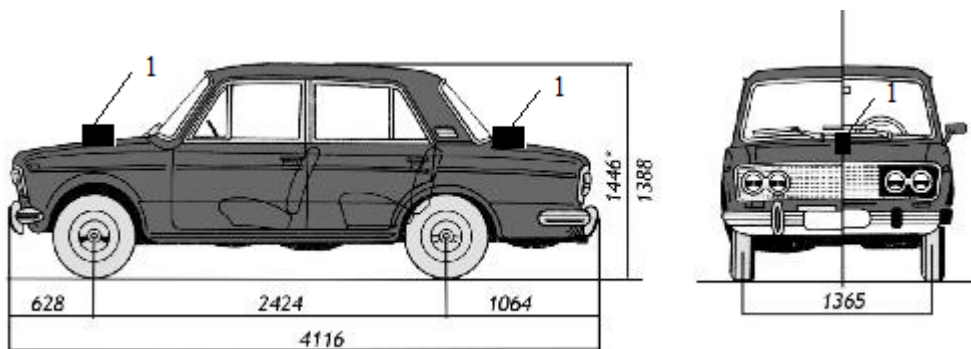

Fig. 5. Location of the antennas: 1 – GPS-antenna

Рис. 5. Расположение антенн на автомобиле: 1 – GPS-антенна



Fig. 6. Location of the antennas (experiment)

Рис. 6. Расположение антенн на автомобиле (эксперимент)

During the research is expected the definition of following:

- Driving stability;
- Entrance into the turn;
- Static steer;
- Maximum speed in a circle on the road with a low coefficient of adhesion;
- Minimum turning radius.

During the experiment the following tests were performed:

- Straight-line motion at a speed of 10 km/h;
- Straight-line motion at a speed of 10 km/h in reverse;
- Clockwise turn at the maximum angle of the drive wheels;
- Counterclockwise turn at the maximum angle of the drive wheels.

The trajectory of the car during experimental studies presented in Fig. 7 and Fig. 8.

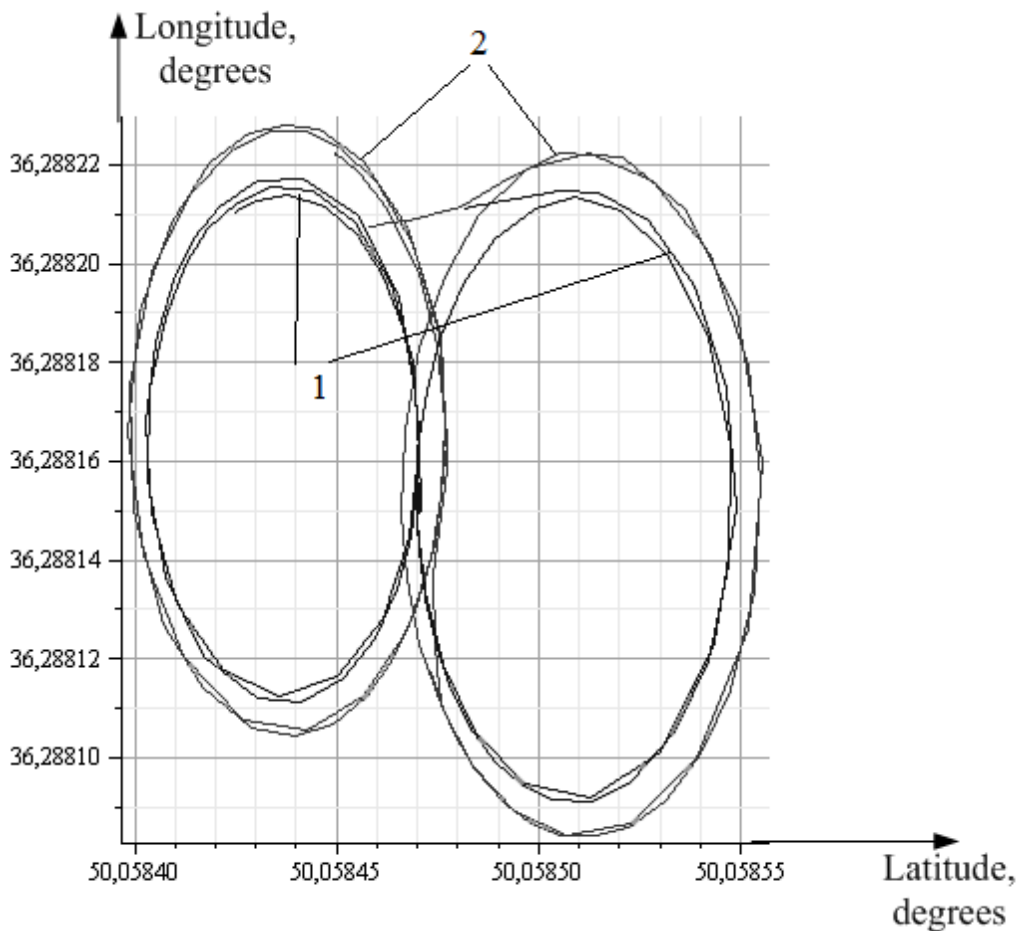

Fig. 7. The trajectory of the car (turns clockwise and counter-clockwise): 1 – the trajectory of the front axle, 2 – the trajectory of the rear axle

Рис. 7. Траектория движения автомобиля (повороты по часовой и против часовой стрелки): 1 – траектория движения передней оси, 2 – траектория движения задней оси



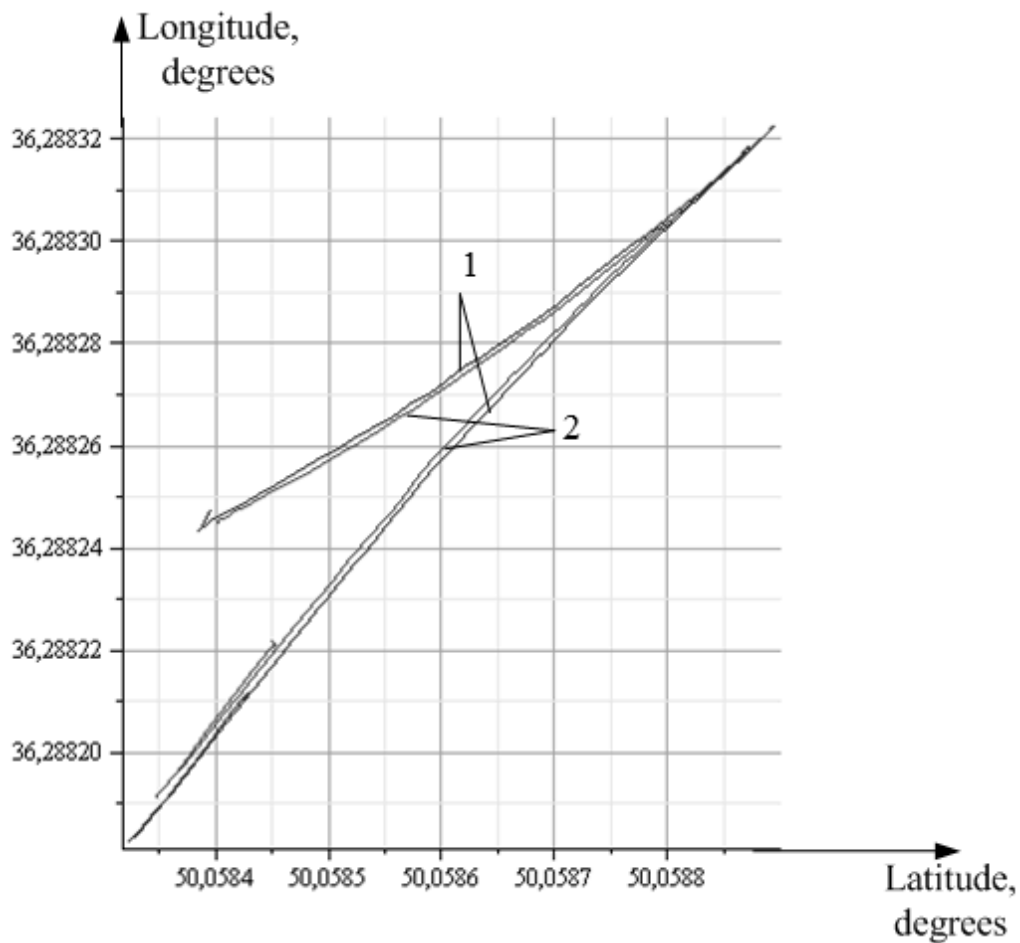

Fig. 8. The trajectory of the car (straight-line motion and straight-line motion in reverse): 1 – the trajectory of the front axle, 2 – the trajectory of the rear axle

Рис. 8. Траектория движения автомобиля (прямолинейное движение и прямолинейное движение задним ходом): 1 – траектория движения передней оси, 2 – траектория движения задней оси

## 5. CONCLUSION

The work investigated the possibility of evaluation of the technical condition of the car by the differential mode GNSS.

The method of differential navigation is a widely used highly accurate measurement results, and not a very complex technical implementation. It allows you to determine the object's location accurate to a few centimeters [5, 7].

Also developed a method for the study of technical state of the TA using a differential mode GNSS.

Implementation process of diagnosing technical state vehicles allows you to:

- reduce the cost of current repairs caused by road and line failures due to the large variation of dispersion durability components and assemblies;
- reduce fuel consumption;
- increase tire life by timely elimination of the factors that contribute to their wear and tear;
- improve the performance of vehicle by continuously maintaining its high dynamic qualities.

In addition, the introduction of the diagnostic process reduces the risk of accidents due to higher quality of service nodes that provide safety.

**Bibliography**

1. Фаробин, Я.Е. *Теория поворота транспортных машин*. Москва: Машиностроение. 1970. 176 p. [In Russian: Farobin, Ya.Ye. *Theory of vehicles rotation*. Moscow: Mashinostroenie].
2. Литвинов, А.С. *Управляемость и устойчивость автомобиля*. Москва: Машиностроение. 1971. 415 p. [In Russian: Litvinov, A.S. *Automobile handling and stability*. Moscow: Mashinostroenie].
3. Конин, В.В. & Харченко, В.П. *Системы спутниковой радионавигации*. Киев: Холтек. 2010. 520 p. [In Russian: Konin, V.V. & Kharchenko, V.P. *Satellite navigation systems*. Kiev: Holtec].
4. Хачатуров, А.А. *Динамика системы дорога — шина — автомобиль — водитель*. Москва: Машиностроение. 1976. 534 p. [In Russian: Hachaturov, A.A. *Dynamics of the road - tire - vehicle - a driver*. Moscow: Mashinostroenie].
5. Kulik, A. & Dergachov, K. & Lytvynenko, T. Development and research of differential mode GNSS model for intelligent transport functioning providing. *Transport Problems*. 2012. Vol. 7. No. 4. P. 71-77.
6. Daily, R.M. & Bevely, D. The Use of GPS for Vehicle Stability Control Systems. *IEEE transactions on industrial electronics*. 2004. Vol. 51. No. 2. P. 270-277.
7. Satirapod, C. & Wang, J. & Rizos, C. Comparing different GPS data processing techniques for modelling residual systematic errors. *Journal of Surveying Eng.* 2003. Vol. 129(4). P. 129-135.
8. *Автотранспортные средства. Управляемость и устойчивость. Технические требования. Методы испытания*. ГОСТ 52302-2004. Москва: Федеральное агентство по техническому регулированию и метрологии. 2005. [In Russian: *Road vehicles. Handling and stability. Technical requirements. Test methods*. Moscow: Federal agency oa technical regulation and metrology].
9. *DL-V3 user manual*. Available at: <http://webone.novatel.ca/assets/Documents/Manuals/om-20000119.pdf>.
10. *Размещение GSM и GPS антенн*. Available at: <http://www.rainbow.by/production/gps/antenna/> [In Russian: *GSM and GPS antennas location*].

Received 27.09.2012; accepted in revised form 15.01.2014