

vehicle suspension; multibody system

Łukasz KONIECZNY*, Rafal BURDZIK, Tomasz FIGLUS

Department of Automotive Vehicle Construction
Faculty of Transport, Silesian University of Technology

*Corresponding author. E-mail: lukasz.konieczny@polsl.pl

USE OF MBS (ADAMS / CAR) SOFTWARE IN SIMULATIONS OF VEHICLE SUSPENSION SYSTEMS

Summary. The results of the examination of a vehicle suspension system in the plate position are presented in the paper. The model vehicle is a Fiat Seicento with front independent suspension, McPherson type, with the steering system and with the semi-trailing arm in the rear suspension. Identification of the model was made by comparing the simulation results with the results from the test stand. A multibody model of the vehicle will be used in studies of the impact of shock absorber technical conditions on the dynamics of automotive vehicles.

WYKORZYSTANIE OPROGRAMOWANIA MBS (ADAMS/CAR) W BADANIACH SYMULACYJNYCH UKŁADU ZAWIESZENIA POJAZDU SAMOCHODOWEGO

Streszczenie. W artykule zaprezentowano przykładowe wyniki badań dynamiki układu zawieszenia pojazdu samochodowego na stanowisku płytowym. Model pojazdu odwzorowuje pojazd marki Fiat Seicento z niezależnym zawieszeniem przednim typu McPherson, z układem kierowniczym oraz wahaczami wleczonymi w zawieszeniu tylnym. Identyfikację modelu przeprowadzono przez porównanie wyników symulacji z wynikami ze stanowiska z wymuszeniem kinematycznym. Zaproponowany wielomasowy model pojazdu zostanie wykorzystany w badaniach wpływu stanu technicznego amortyzatorów pojazdów samochodowych na dynamikę pojazdu.

1. INTRODUCTION

The ADAMS software is a commercial program which enables the creation of an MBS multibody system with a considerable amount of degrees of freedom, constructed with elements of concentrated masses. The program is of modular construction, which consists of many applications with specific purposes for given modules, e.g. railway, aviation or vehicles and different applications, e.g. safety [3]. The models in the software have such a construction that the system consists of inflexible bodies or deformable ones connected in a specific way (spherical, sliding, rotary joints), moving under the influence of the action of moments and force of different kinds (concentrated or separating forces, force of contact). The software is used to solve the tasks connected with system kinematics (setting the movement of individual segments) and dynamics (setting the movement of a system in assemblies which do not limit the maneuver rates, taking into account the masses and forces in the system - they must be defined material properties) [1, 4, 7, 9].

In the ADAMS software the equations of motion by the Lagrange method of the second type in the absolute coordinates for the composed systems are generated. The integral procedures used to solve the differential-algebraic equations can be divided into two groups. The first one includes the multistep algorithms with changing orders and with changing and stable steps. The second group includes the one-step algorithm where the Runge-Kutta-Feheleberg method is used (RFK45) [2, 6, 10-15].

The Adams/Car system enables the creation and simulated examination of individual car subsystems, such as: suspension, the steering gear, driving system and their compounds in a car. The program contains a great library with different constructions used in cars. The geometry and the relationships between individual parts are included in the library, and the operation of the user is limited to defining the place of assembly in the space. The example construction solutions of suspension systems accessible in the library are presented in fig. 1 [15]. The McPherson front suspension and semi-trailing arm rear suspension used in the construction of the vehicle model are also presented.

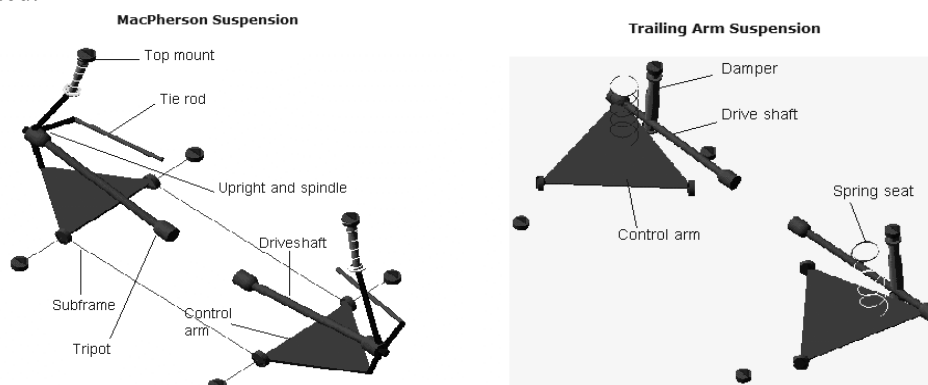

Fig. 1. View of McPherson front suspension and semi-trailing arm rear suspension

Rys. 1. Widok zawieszenia przedniego typ McPherson oraz zawieszenia tylnego typu wahacze wleczone

In the subsequent step of constructing the suspensions, the location values were introduced for the design points defining the mutual position of elements in the suspension system. Fig. 2 shows the front and rear suspension systems in the modeled vehicle, along with a table of characteristic points.

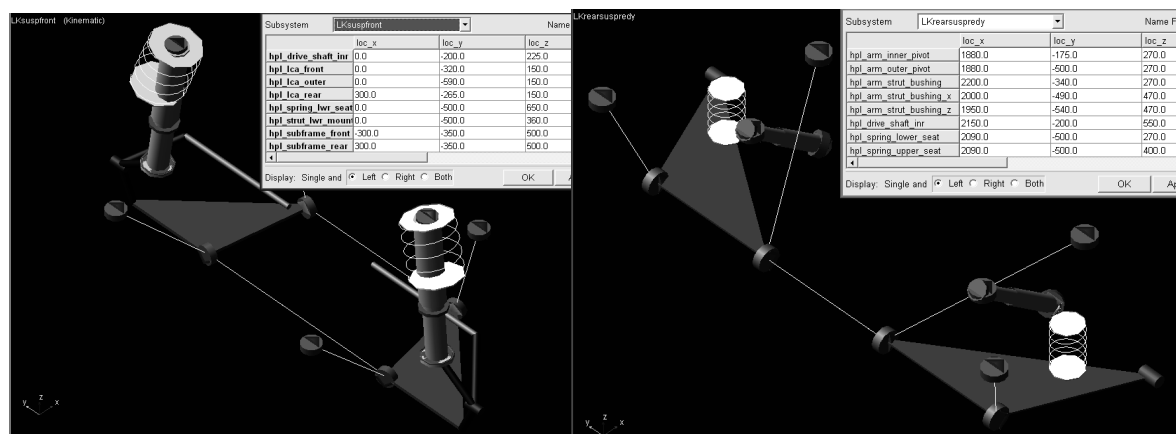

Fig. 2. View of front and rear suspension with a table of design points' location

Rys. 2. Widok układu zawieszenia przedniego oraz tylnego z tabelą położenia punktów konstrukcyjnych

The suspension model consists of bushes which joins the suspension with the frame, the socket of the steering column and other elements of suspension system. The metal-rubber bushes joining the suspension with the frame are characterized as resilient. The elements, such as coil spring and damper

[5, 8], are defined by giving their characteristics. The characteristics used in the model are presented in fig. 3-5.

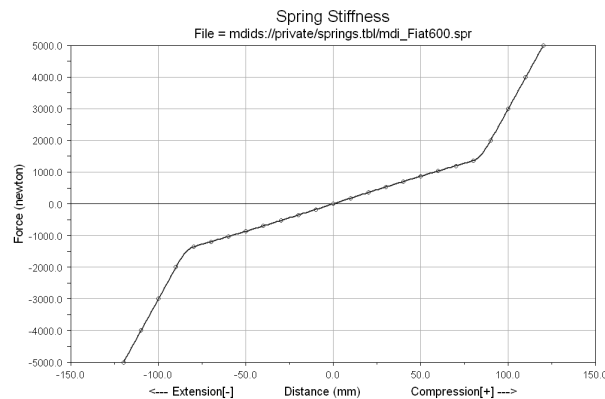

Fig. 3. The view of spring characteristics
Rys. 3. Widok charakterystyki sprężyny

In the case of the spring characteristic the curve is progressive. Outside the range of wheel deflection the spring cooperation with bumper causing the collapse of the characteristics of the spring.

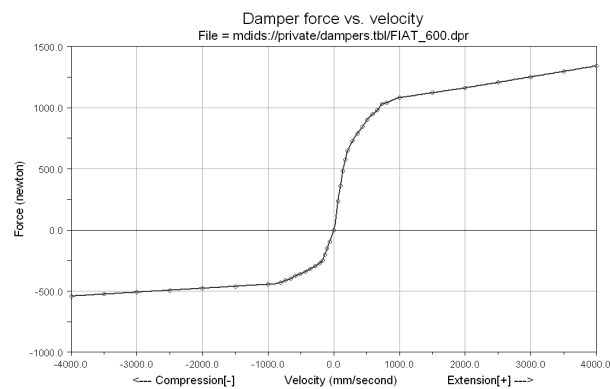

Fig. 4. The view of damper characteristics
Rys. 4. Widok charakterystyki amortyzatora

The example of front shock absorber damping characteristics is non-linear and non-symmetrical (damping force for extension is about 2 times greater than in compression).

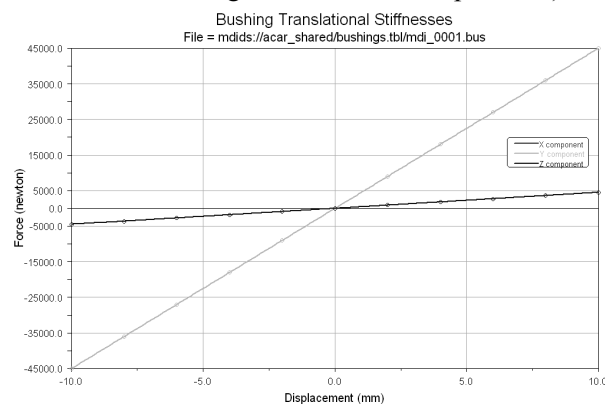

Fig. 5. The view of metal-rubber bush characteristics
Rys. 5. Widok charakterystyki sprężystości tulei metalowo-gumowej

For metal-rubber bushing characteristics of elasticity are given for all three possible directions of movement.

2. SIMULATION RESEARCH

Within the framework of the simulated examination a vehicle model of a Fiat Seicento with the front independent suspension, McPherson type, with the steering system and with a semi-trailing arm in the rear suspension was developed. The examined system of the complete vehicle consists of 49 kinematic degrees of freedom. There are 42 gruebler count (approximate degrees of freedom), 40 moving parts (not including ground) 6 cylindrical joints, 9 revolute joints, 4 spherical joints, 5 translational joints, 2 convel joints, 8 fixed joints, 4 hook joints, 1 inline primitive joint, 1 inplane primitive joint, 5 perpendicular primitive joints, 10 motions and 2 couplers. The possibilities of using in simulation the Adams/Car /Ride module allows the testing of vehicle dynamics forcing the position of the plate of the test stand. The virtual model of the vehicle is set on four servo-motors. They can control any combination of excitation of individual actuators (displacement and amplitude, phase between extortion, etc.) and determine all kinds of vibration (vertical, lateral, angular).

The vehicle model on the test rig is presented in fig. 6.

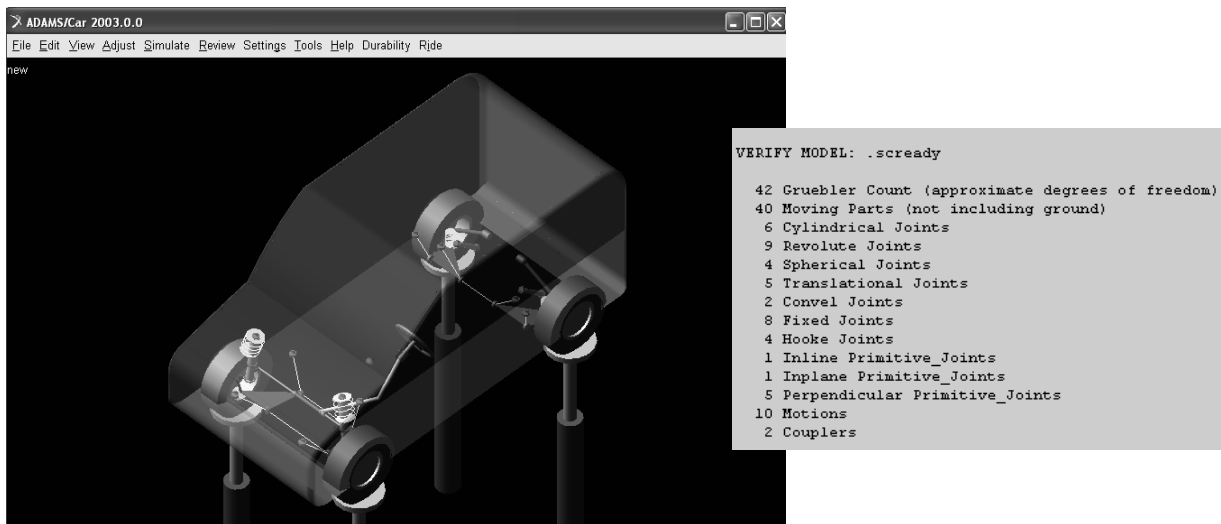

Fig. 6. The complete view of the vehicle on the test rig

Rys. 6. Widok pełnego pojazdu na płytach stanowiska

Within the framework of the preliminary examination the vibration test was conducted. The kinematic forcing, which operated on the individual wheels at the constant forcing amplitude – 8 mm and the growing frequency from 0 to 20 Hz was used (the test regulation is close to the rules of operating devices at the vehicle inspection station used to examine the efficacy of muffling the dampers). The simulation was conducted for a 10-second test and 1000 computational steps. Fig. 7. presents the time signal of the displacement of the inducing plate during the test, and fig. 8. presents the FFT3D spectrum generated for this signal. The module of developing results (postprocessor) enables the display of the simulation animation and the graph of the course of the chosen parameters (force, velocity, displacement, angles, etc.). In the program frequency analysis may be carried out for these signals (algorithm FFT and STFT – with choosing the window type, the length of a single part for FFT, and the percentage value of overlay windows).

The harmonic extortion applied in the model identification process allows an assessment of the dynamic properties of the model. The time course of a typical excitation, presented in fig. 8, also corresponds to the force exhibition used in the EUSMA shock absorber test method. For the needs of the identification of the model of the whole vehicle, the vibration acceleration values were determined on the inducing plate and on the vehicle wheel (fig. 11). The researches were made on a harmonic test stand (kinematic extortion) with continuous frequency regulation (in the range 0-21.5 [Hz]) and constant displacement amplitude 0.008 [m] (fig. 9). This stand is in the Laboratory of Vehicle Dynamics in the Department of Vehicle Construction, Faculty of Transport, Silesian University of

Technology. The data acquisition card μ DAQ 30 was used, connected with a personal computer by the USB port. A ADXL321 accelerometers ($\pm 18g$ -range) were used, mounted on the wheel (fig.10a) and the platform of the test stand (fig. 10b), produced by Analog Devices.

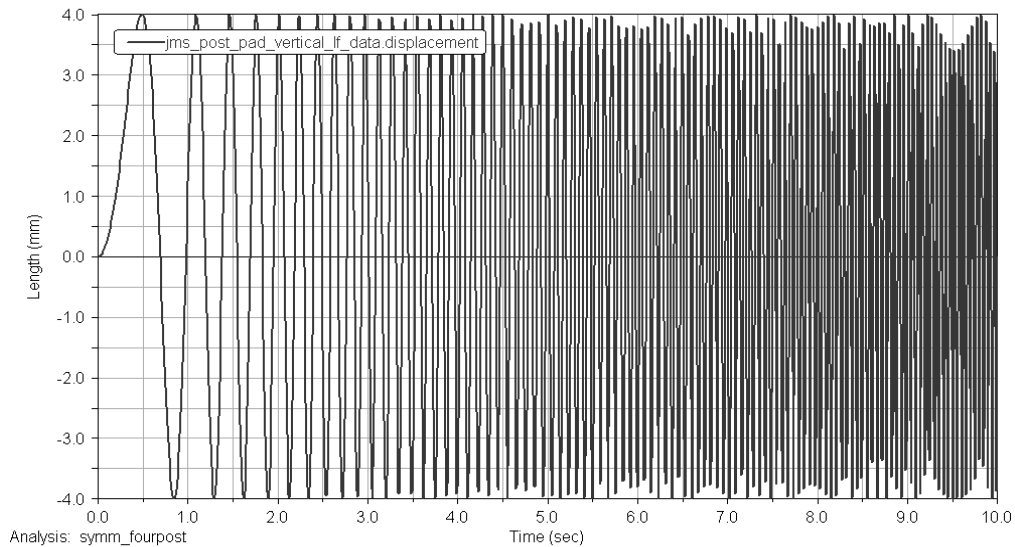

Fig. 7. Displacement of the test stand plate
Rys. 7. Przemieszczenia płyty wymuszającej

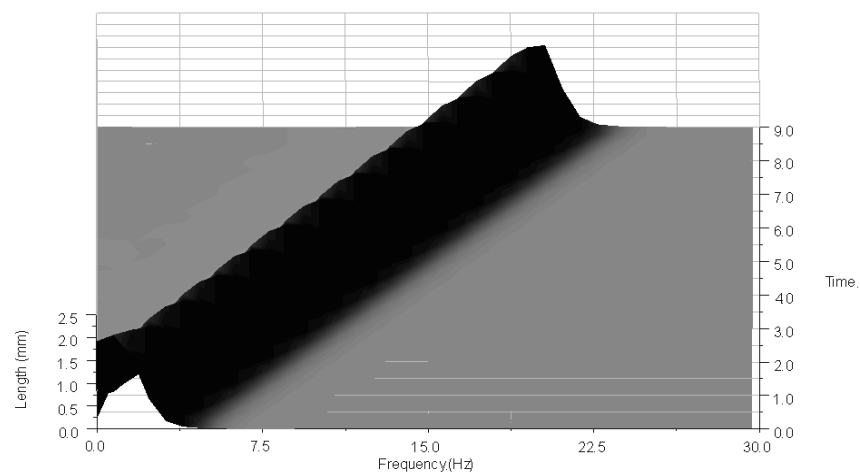

Fig. 8. The FFT3D spectrum for displacement of the test stand plate
Rys. 8. Widmo FFT3D dla przemieszczeń płyty

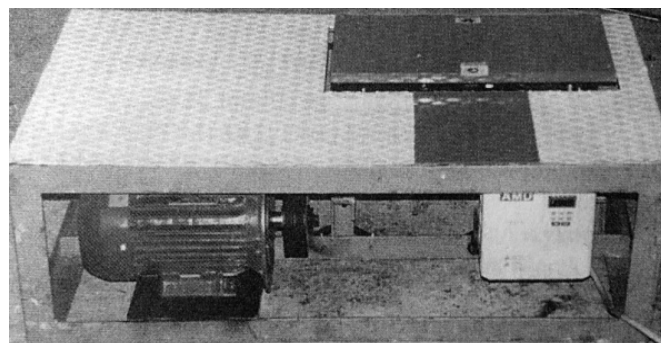

Fig. 9. Plate test stand
Rys. 9. Stanowisko płytowe

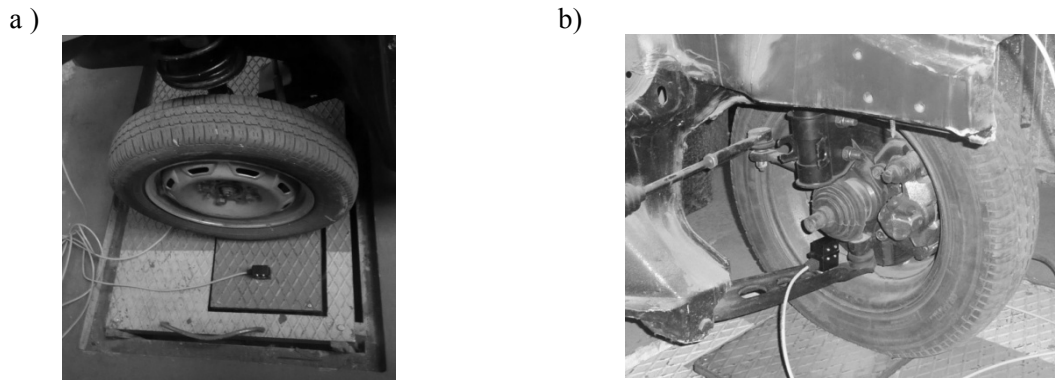

Fig. 10. Location of vibration acceleration sensors on the plate (a) and on the wheel (b)
 Rys. 10. Lokalizacja czujników przyspieszeń drgań na płycie (a) oraz na kole pojazdu (b)

Real recorded signals of accelerations are noisy, so the signals are filtered by a zero phase filter in Matlab software.

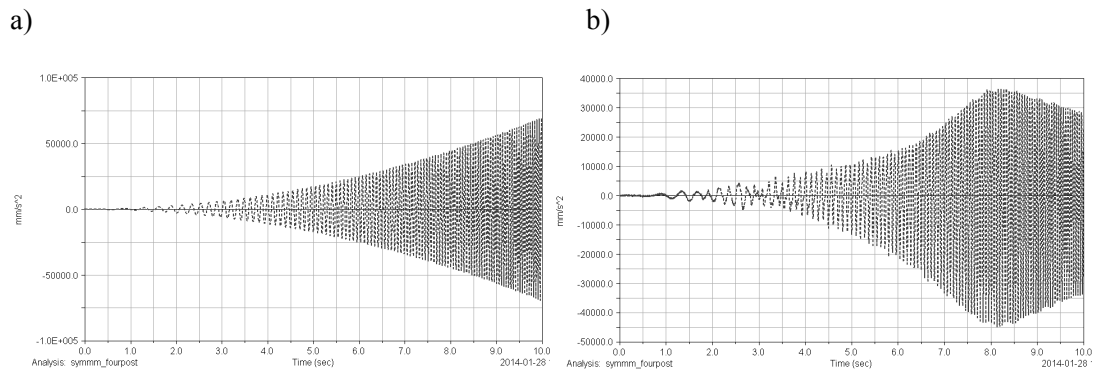

Fig. 11. Course of the vibration acceleration of the inducing plate (a) and the wheel (b) – Adams/Car simulation
 Rys. 11. Przebieg przyspieszeń drgań płyty wymuszającej (a) oraz koła (b) – symulacja Adams/Car

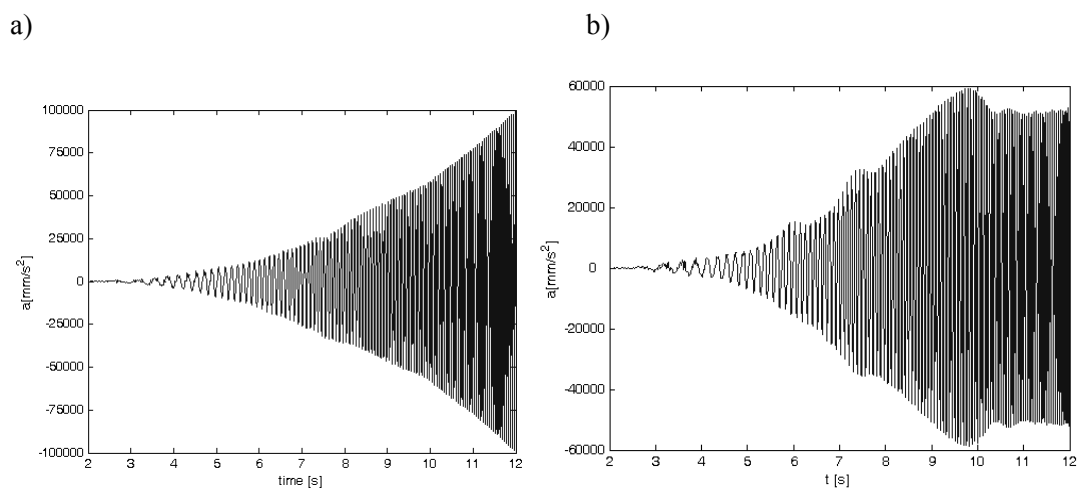

Fig. 12. Course of the vibration acceleration of the inducing plate (a) and the wheel (b) – measurement at the test stand

Rys. 12. Przebieg przyspieszeń drgań płyty wymuszającej (a) oraz koła (b) – pomiar na stanowisku

A qualitative comparison of the vibration acceleration time course obtained from the vehicle model simulated in the Adams/Car application (fig. 11) and the time course obtained from experimental examinations on the plate test stand (fig. 12) corroborates the correct identification of the model. The insignificant quantitative differences (in acceleration amplitudes) may result from the assumption of theoretical values for some of the parameters (moments of inertia of the wheels and the whole vehicle, location of the vehicle's gravity centre).

3. CONCLUSION

The results present the process of model validation. The spring and damper characteristics were worked out in the lab examination. The suspension special points, which defines suspension kinematics, were measured in a laboratory. The results confirmed good correlation of the presented simulation results and the experimental examination results from the test stand with kinematic harmonic extortion. The multibody model of the vehicle will be used in studies of the impact of shock absorber technical conditions on the dynamics of automotive vehicles.

Bibliography

1. Blacha, L. Removal of lead from copper alloys during vacuum refining. *Archives of metallurgy*. 2003. Vol. 48. No. 1. P. 105-127.
2. Blundell, M. & Harty, D. *Multibody systems approach to vehicle dynamics*. Oxford: Elsevier Butterworth – Heineman, Linacre House, Jordan Hill. 2004.
3. Drożdżiel, P. & Opielak, M. & Rybicka, I. Bezpieczeństwo transportu pasażerskiego w komunikacji miejskiej. *Logistyka*. 2012. No. 3. P. 513-520. [In Polish: Drożdżiel, P. & Opielak, M. & Franky, I. Safety of passenger in public transport. *Logistics*.]
4. Fornalczyk, A. & Saternus, M. Platinum recovery from used auto catalytic converters in electrorefining process. *Metallurgija*. 2013. Vol. 52. No. 2. P. 219-222.
5. Hudák, A. Magnetorheological damping. In: *XLII. International Scientific Conference of Czech and Slovak University Departments and Institutions dealing with the research of combustion engines*. Žilina. Slovakia. September 8 – 9, 2011.
6. Hurel, J. & Mandow, A. & García-Cerezo, A. Kinematic and dynamic analysis of the McPherson suspension with a planar quarter-car model. *Vehicle System Dynamics: International Journal of Vehicle Mechanics and Mobility*. 2013. Vol. 51. No. 9. P. 1422-1437.
7. Klimpel, A. & Dobrzański, L.A. & Janicki, D. & Lisiecki, A. Abrasion resistance of GMA metal cored wires surfaced deposits. *Journal of materials processing technology*. 2005. No. 164/165. P. 1056-1061.
8. Konieczny, Ł. & Burdzik, R. & Warczek, J. The uncertainty of determining shock absorber damping characteristic on indicator test stand. *Diagnostyka*. 2013. Vol. 14. No. 2. P. 63-66.
9. Michalski, R. & Wierzbicki, S. An analysis of degradation of vehicles in operation. *Eksploatacja i Niezawodność – Maintenance and Reliability*. 2008. Vol. 1(37). P. 30-32.
10. Ning, X. & Zhao, C. & Shen, J. Dynamic Analysis of Car Suspension Using ADAMS/Car for Development of a Software Interface for Optimization. In: *International Workshop on Automobile, Power and Energy Engineering*. Wuhan 15-17.04.2011. Book Series: Procedia Engineering. 2011. Vol. 16.
11. Wojtyra, M. & Frączek, J. *Metoda układów wieloczłonowych w dynamice mechanizmów. Ćwiczenia z zastosowaniem programu ADAMS*. Warszawa: Oficyna Wydawnicza Politechniki Warszawskiej. 2007. [In Polish: Wojtyra, M. & Frączek, J. *Method of multibody constructions in dynamics of mechanisms. Exercises using the ADAMS program*. Warsaw: Publishing House of Warsaw University of Technology.]
12. Wang, Z. & Yu, Z. & Li, K. Research of Automobile Tire Vertical Stiffness Optimization Method on the Basis of ADAMS/Car. In: *Advanced Polymer Processing International Forum (APPF)*

- 2012). Qingdao Univ Sci & Technol, Qingdao 28-30.09.2012. Book Series: Key Engineering Materials. 2013. Vol. 561. P. 527-532.
13. Tang, A. Modeling and Validation of MBS using Joint Force Actuator in ADAMS Car. In: *3rd International Conference on Manufacturing Science and Engineering (ICMSE 2012)*. Location: Xiamen 27-29.03.2012. Book Series: Advanced Materials Research. 2012. No. 482-484. P. 2257-2260.
 14. Zheng, S. & Cao, J. & Feng, J. Simulation analysis of traditional and L type Macpherson suspension based on ADAMS/Car. In: *3rd International Conference on Manufacturing Science and Engineering (ICMSE 2012)*. Xiamen 27-29.03.2012. Book Series: Advanced Materials Research. 2012. No. 479-481. P. 1515-1521.
 15. *Adams User Guide*. ADAMS 2003.

Received 01.07.2012; accepted in revised form 22.01.2014