

tribological contact, electrification of sand, contact "wheel-rail"

**Nikolai GORBUNOV, Alexander KOSTYUKEVICH,  
Katherine KRAVCHENKO, Maxim KOVTANETS\***  
East-Ukrainian National University named after V. Dal  
Molodyozhny block, 20a, Lugansk, 91034, Ukraine  
\*Corresponding author. E-mail: kkatherina@ukr.net

## **THE EFFECT OF THE ELECTRIFICATION OF SAND ON THE INTERACTION OF FRICTION IN TRIBOLOGICAL CONTACT**

**Summary.** In the article questions of the effectiveness of the presence of abrasive granular material in contact "wheel-rail" in the implementation of the optimal traction and its quantity on the surface of the rail. A method for determining the charge abrasive particles. Experimentally proved the effectiveness of electrification of sand before applying it to tribocontact to improve traction.

## **О ВЛИЯНИИ ЭЛЕКТРИЗАЦИИ ПЕСКА НА ФРИКЦИОННОЕ ВЗАИМОДЕЙСТВИЕ В ТРИБОКОНТАКТЕ**

**Аннотация.** В статье рассмотрены вопросы эффективности наличия абразивного сыпучего материала в контакте «колесо-рельс» при реализации тягового усилия и оптимального его количества на поверхности рельса. Приведена методика определения заряда частиц абразивного материала. Экспериментально доказана эффективность электризации песка перед подачей его в трибоконтат для повышения сцепления.

### **1. INTRODUCTION**

The improvement of frictional properties of tribotechnical system "wheel-rail" due to design, materials science, and technological factors, contributes to the creation of potentially high-friction properties of the system, but do not guarantee the implementation of traction without slipping wheels. This can be explained by the dominant influence of climatic and weather conditions of the locomotive at operation on the frictional properties of the tribosystem. The most effective means of evening out this influence was the use of sand. There are some other materials that contain abrasive particles: marble chips, ground blast furnace slag etc., which are used to increase traction, but are not widely found.

The sand systems used do not provide the required amount of sand in a contact to achieve high coupling characteristics of the engine that reduces the efficiency of these systems and leads to excessive consumption of sand. Experimental studies [1] found that an increased amount of abrasive granular material in the contact zone of the wheel with the rails reduces the coefficient of the wheel coupling with the rail. Therefore, Y.M. Luzhnov [2] proposed to regulate the amount of sand applied to the contact, depending on the amount of moisture or contamination of the rails surface and the speed of the locomotive. N.N. Kamenev and Y.I. Osenin in their works [3, 4] showed that to

provide high traction properties of the locomotive a certain amount of sand with its distribution along its raceway in a single layer should be applied to the wheel when it contacts with the rail.

## 2. MATERIAL RESEARCH

To achieve the distribution of abrasive material in a single layer it is proposed to electrify it before applying it to the wheel when it contacts with the rail.

A series of experiments on the electrification of abrasive granular material has been made on a laboratory installation (Fig. 1). When carrying out the experimental studies the input voltage regulated by the laboratory autotransformer (LATR) ranging from 0 V to 220 V was applied on the primary winding of high voltage transformers (Tr-r 1, Tr-r 2), connected in series. When the installation was on, there was an electric field in the charging device, under which the abrasive particles acquired charges  $q_{pi}$ .

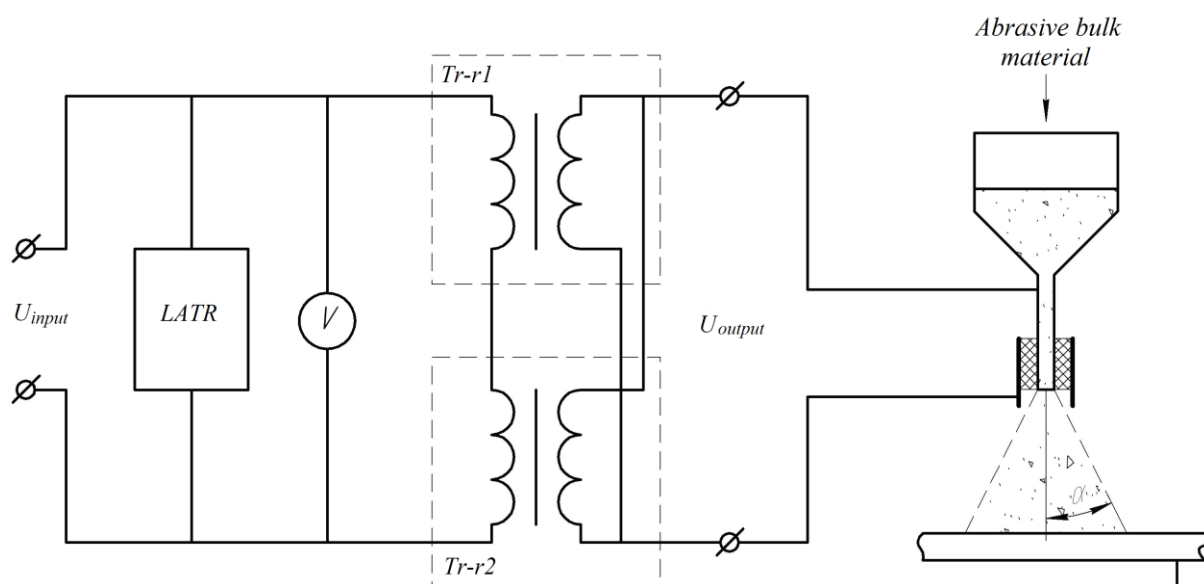

Fig. 1. The scheme of charging and the supply of abrasive particles on metal surfaces

Рис. 1. Схема зарядки и нанесения абразивных частиц на поверхность металла

The experiments carried out shows that when the electrification of the particles takes place, they are evenly distributed on the metal surface in one layer. Registered in the experiments, the photographs are presented in Figures 2, which clearly demonstrates the difference between scattering sand with the electrification of abrasive particles (Fig. 2b) and without it (Fig. 2a). The input voltage of transformers applied to the coil inlet was 14 kV. The time since the mechanical valve had been opened in both experiments was 3 seconds. Figure 2 shows that when the electrification is absent, there is a negative phenomenon for the wheel coupling with the rail that is the small hill, while the charged abrasive particles are uniformly distributed along the surface in one layer and are kept on it.

To simplify the task of determining the electric charge it is assumed that the nozzle, which is under high voltage and from which the abrasive bulk material is fed, is a uniformly charged filament (Fig. 3). Such simplification is based on the fact that the radius of the sand scattering is much greater than the radius of the nozzle [5].

The given theoretical and experimental studies have proved that the angle of sand scattering depends on the electric charge applied to the abrasive mixture. The determination of the charge depending on the design of nozzles should be done according to the following system of differential equations:

$$\left. \begin{aligned} m_n y &= -E_{oy} \cdot q_n + m_n \cdot g - F_{conpy} + \frac{\varepsilon_0 \cdot (\varepsilon - 1)}{2} \cdot v \cdot (E_{oy})^2; \\ m_n r &= E_{or} \cdot q_n - F_{conpr} + \frac{-\varepsilon_0 \cdot (\varepsilon - 1)}{2} \cdot v \cdot (E_{or})^2 \end{aligned} \right\} \quad (1)$$

where:

$m_n, q_n$  – mass and charge of the abrasive particle;  
 $E_{oy}, E_{or}$  – field strength for the electrostatic charging;  
 $F_{conpy}, F_{conpr}$  – resistance of the air to particle motion;  
 $\varepsilon_0$  – dielectric penetrability of the medium;  
 $\varepsilon$  – electric constant.

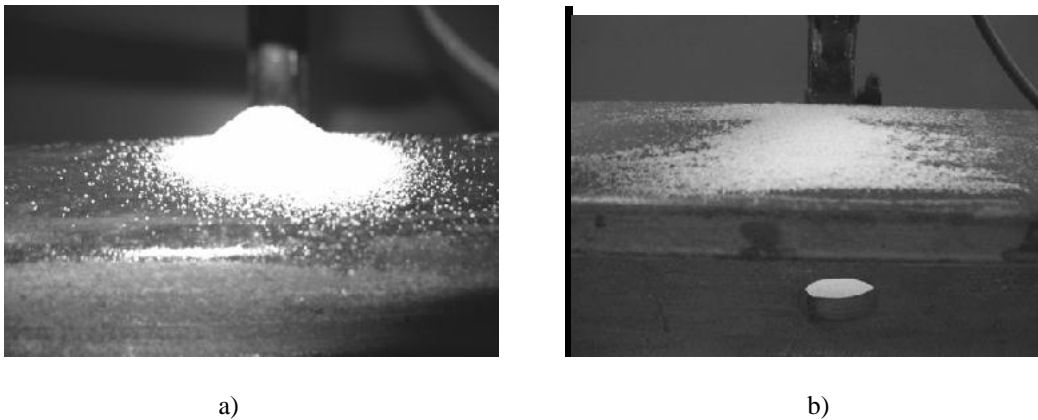

Fig. 2. Photographic recording of sand scattering: a - without electrostatic charging, b - with electrostatic charging

Рис. 2. Фотографическая запись рассеяния песка: а - без электростатического заряда, б - с электростатической зарядкой

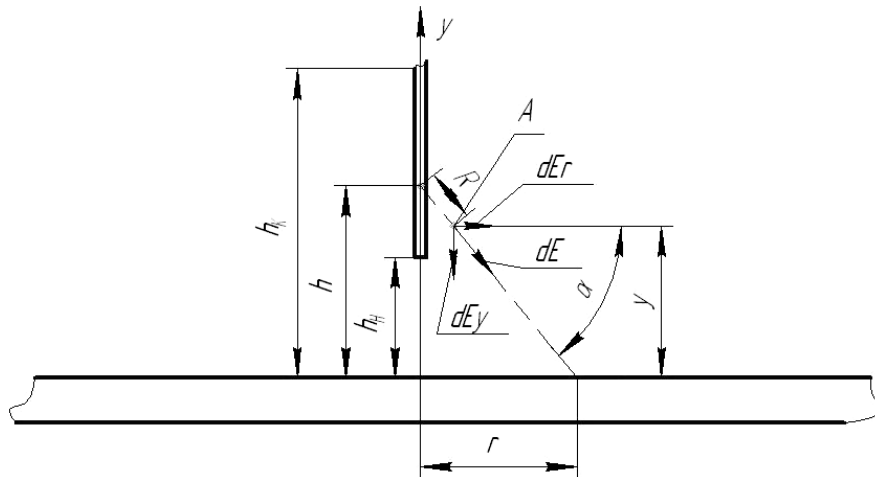

Fig. 3. The calculation scheme

Рис. 3. Расчетная схема

The simulation revealed that to achieve an effective distribution of sand in the wheel contacting with a rail with the width of 60 mm, the voltage applied to the charging unit must be equal to 450 V, whereas an electric charge of grains should be  $1,502 \cdot 10^{-11}$  C (15 pC).

The calculation results showed that the distribution of sand in contact with the moving locomotive with the speed above 3,8 km / h is significantly affected by the force of air resistance arising from the movement of the locomotive and the crosswinds. To achieve the desired distribution of sand on the

surface of the rail, the voltage should be increased with the increase in the speed of the environment. For example, when the locomotive speed is 11 km / h the voltage must increase by 1,78 times (Fig. 4).

According to electrostatics, electrified and polarized abrasive bulk material is better besieged on a clean surface. Since the wheel and rail groove is cleaner, the sand is likely to be distributed there. Taking into account the given circumstance, we find that the consumption of sand under the permissible moisture content ( $W \leq 0,5\%$ ) is decreased by 25 times.

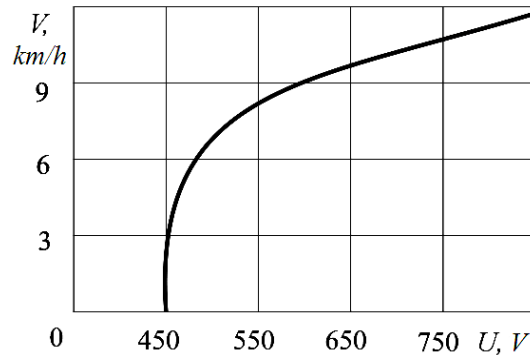

Fig. 4. The dependence of the applied voltage  $U$  to the charging device on the speed of the locomotive  $V$   
Рис. 4. Зависимость приложенного напряжения  $U$  к зарядному устройству от скорости локомотива  $V$

The investigation of the influence of electrification of abrasive granular material on the parameters of frictional interaction of the friction pair were carried out on the poster installation "friction machine", set at the Department of Railway Transport of the East-Ukrainian National University named after Volodymyr Dahl.

When conducting the research, the following frictional contact conditions have been used:

- rails covered by water;
- rails covered by oil.

Every frictional condition has been investigated when:

- the sand is not in contact;
- the sand is in contact;
- the electrified sand is in contact.

As a result of processing the experimental data, the dependences of the friction coefficient on the temperature at different friction conditions have been obtained (Fig. 5, 6). The dependences obtained are well described by a system of two polynomial equations:

$$\begin{cases} f(\theta) = a_0 + a_1\theta + a_2\theta^2 + a_3\theta^3 + a_4\theta^4 + a_5\theta^5 + a_6\theta^6 & \text{npu } \theta \leq \theta'; \\ f(\theta) = a_0 + a_1\theta + a_2\theta^2 + a_3\theta^3 + a_4\theta^4 + a_5\theta^5 + a_6\theta^6 & \text{npu } \theta > \theta', \end{cases} \quad (2)$$

where:

$f$  - the friction coefficient;

$\theta$  - the temperature in contact, °C;

$a_0, a_1, a_2, a_3, a_4, a_5, a_6$  - polynomial coefficient (are given in tab. 1);

$\theta'$  - temperature gap of two graphs, °C.

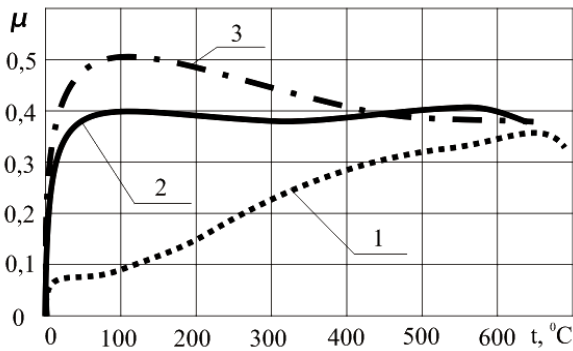

Fig. 5. The dependence of friction coefficient on temperature when supplying an electrified sand on the watered rails: 1 – without sand; 2 – with sand; 3 – with electrified sand

Рис. 5. Зависимость коэффициента трения от температуры при подаче заряженного песка на мокрые рельсы: 1 – без песка; 2 – с песком; 3 – с заряженным песком

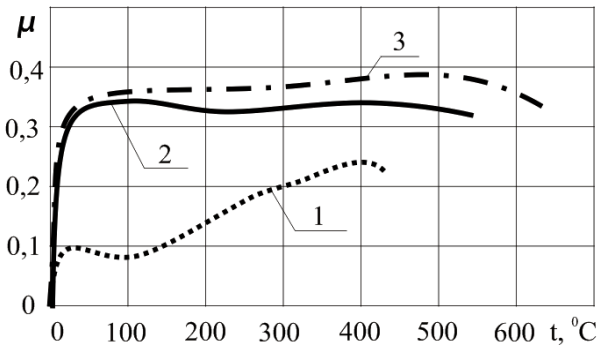

Fig. 6. The dependence of friction coefficient on temperature when supplying the electrified sand on the oiled rails: 1 – without sand; 2 – with sand; 3 – with electrified sand

Рис. 6. Зависимость коэффициента трения от температуры при подаче заряженного песка на замасленные рельсы: 1 – без песка; 2 – с песком; 3 – с заряженным песком

The supply of an electrified sand to the oiled rails can improve the coefficient of friction in the contact from 0,25 to 0,4 (Fig. 6), for the rails covered by water - from 0,35 to 0,5. Compared with the supply of non- electrified sand, the friction coefficient for oiled rails is increased by 16%, for the rails covered by water - by 20%.

The obtained dependences of the friction coefficient on the temperature allowed to improve the mathematical model of the frictional interaction of wheels and rail-track, considering the electrified sand in contact. According to this model, the coupling characteristics (Fig. 7, 8) in respect of the electrification of abrasive granular material have been made.

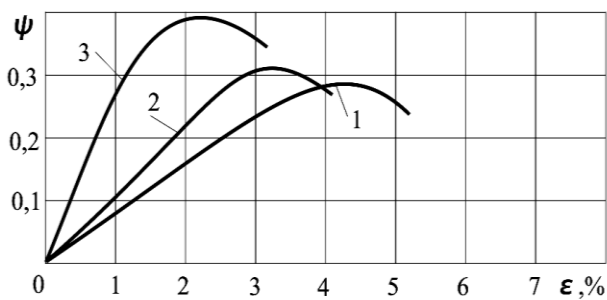

Fig. 7. Characteristics of coupling on the watered rails: 1 – without abrasive material; 2 – with sand; 3 – with electrified sand in the contact

Рис. 7. Характеристики сцепления для мокрых рельсов: 1 – без абразивного материала; 2 – с песком; 3 – с заряженным песком в контакте

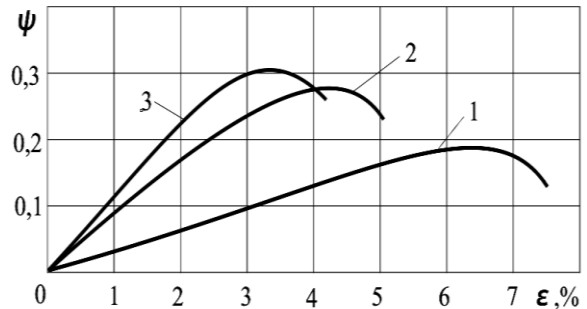

Fig. 8. Characteristics of coupling on the oiled rails: 1 – without abrasive material; 2 – with sand; 3 – with electrified sand in the contact

Рис. 8. Характеристики сцепления для замасленных рельсов: 1 – без абразивного материала; 2 – с песком; 3 – с заряженным песком в контакте

Table 1

## Polynomial coefficient

Friction state rail	$\theta', \circ$	$a_0$	$a_1$	$a_2$	$a_3$	$a_4$	$a_5$	$a_6$
Covered by water	$\leq 20$	0	0.0441141	-0.0104577	0.0011374	-5.6384571E-5	1.0349606E-6	
	$> 20$	0.0681197	0.0005314	-8.6497810E-6	7.6717155E-8	-2.4532325E-10	3.36940042E-13	-1.6937496 E-16
Covered by water + sand	$\leq 30$	0	0.0438862	-0.0026390	8.6087216E-5	-1.1216844E-6		
	$> 30$	0.3482576	0.0010877	-7.3352315E-6	1.7344158E-8	-1.3175956E-11		
Covered by water + electrified sand	$\leq 30$	0	0.0479149	-0.0026575	9.2997763E-5	-1.3971691E-6		
	$> 30$	0.4117805	0.0015435	-8.4811285E-6	1.5062552E-8	-8.9142487E-12		
Covered by oil	$\leq 30$	0	0.0405710	-0.0094858	0.0011079	-6.4996751E-5	1.8375838E-6	-1.9908502E-8
	$> 30$	0.0656233	0.0025552	-6.215575 E-5	5.7655971 E-7	-2.3837662 E-9	4.5958668E-12	-3.3776468 E-15
Covered by oil + sand	$\leq 20$	0	0.0523847	-0.0036953	9.3564089 E-5			
	$> 20$	0.2506320	0.0027274	-2.8647801E-5	1.3325902E-7	-3.0612494E-10	3.4239912E-13	1.5031845E-16
Covered by oil + electrified sand	$\leq 30$	0	0.0602758	-0.0053273	0.0002176	-3.2169923 E-6		
	$> 30$	0.3173138	0.0004876	3.0611680 E-6	8.4734179 E-9	-7.6169029 E-12		

The supply of sand to the watered rails increases the coupling coefficient by 12,9%, with a decrease in slip by 23,8% (Fig. 7). When supplying sand to the oiled rails, the coupling coefficient increases by 31%, the slip is reduced by 37% (Fig. 8). The supply of an electrified sand to the watered contact compared to non-electrified allows to increase the friction coefficient from 0,31 to 0,39, and the slip is reduced from 3,2 to 2,2 (Fig. 7). The advantage of electrified sand on the oiled contact comparing to the non-electrified sand is an increase in coupling coefficient from 0,27 to 0,3 and a decrease in slip - from 4,2 to 3,2 (Fig. 8) [6].

According to the method described in [7], the possibility of reducing the fuel consumption for the engine traction with a decrease in slip in the wheels contacting with the rail when supplying an electrified sand has been estimated. For this, the slip difference of axles when supplying sand and when supplying the electrified sand has been previously determined. For the consideration received in a total path length ( $L = 100$  km), which is a locomotive with the sand in one tank filling the sandbox (the mass of sand occupied the bunker is 1000 kg, performance sandbox 0,8 kg/min). The use of electrified sand compared to non-electrified one (Fig. 7) allows to reduce the slip by 1% and respectively, the way of slipping due to the skidding on considered track of  $L = 100$  km will be reduced to  $l = 100$  m.

The work  $A$ , which a locomotive 2TE116 used for friction in the contact of wheels with the rails [7]:

$$A = lP_o fn1000, \quad (3)$$

where:

$l$  – a slip way of the moving axles due to the skidding, m;

$P_o$  – average load of the wheels on the rails, kH;

$f$  – coefficient of friction;  $n$  – a number of axes used in the skidding.

According to the primary data (Table 2) the work of friction is equal to 271,2 MJ, which corresponds to heat consumption of  $B = 64880$  kcal. To perform this work a locomotive must have such fuel consumption as:

$$G_1 = \frac{B}{\eta_m Q_m} = 20,52 \text{ kg}, \quad (4)$$

where:

$\eta_m$  – efficiency of the locomotive;

$Q_m$  – heating value of fuel, kcal / kg.

Table 2

Primary data for calculations

$P_o, \text{кН}$	$f$	$n$	$\eta_m$	$Q_m, \text{kcal / kg}$	$b, \text{kg / } 10^4 \text{ m} \cdot \text{km gross}$	$Q, \text{t}$
226	0,2	6	0,31	10200	25	2500

The total fuel consumption on the given track is 625 kg [7]:

$$G_0 = \frac{LQb}{10000} = 625 \text{ kg}, \quad (5)$$

where:

$b$  – fuel consumption of the operational fuel gauge (10000 tkm gross),

$Q_m$  – mass of the stock, t.

Comparing the total fuel consumption of the locomotive with the fuel that is saved due to the reduced slip when supplying electrified sand, it is clear that the fuel consumption will decrease by 3,3%.

### 3. CONCLUSION

In the current study we found that to have an effective distribution of sand in the contact (in one layer where the distance between the particles is equal to three particle radius), the particle of sand must be provided by a charge equal to 15 pC, and an electrical voltage in the charging device must be equal to 450 V. When the locomotive moves with the speed above 3,8 km / h, the trajectory of the sand particles is influenced by the force of aerodynamic resistance of air, that's why when the speed is increased, the voltage must be also increased. The proposed method of supplying an electrified sand allows to increase the friction coefficient on the oiled rails by 10% compared with the supply of non-electrified sand, and with a decrease in slip - by 21,48%, on the watered rails - by 20,5%, and with a decrease in slip - by 31,35%. The consumption of fuel is reduced by 3,3%.

### References

1. Кед Н.Н., Чуверин Ю.Ю., Чумавотов А.И.: *Повышение эффективности применения песка для улучшения сцепления колес локомотивов с рельсами*. Межвузовский сб. науч. тр., МИИТ, 1984, р. 105-108.
2. Лужнов Ю.М., Попов В.А., Седов Г.М.: *Модель фрикционного контакта колеса с рельсом и возможности управления его свойствами*. Вестник ВНИИЖТ. Вып. №1. – 2009, р. 30-32.
3. Каменев Н.Н. *Эффективное использование песка для тяги поездов*. – М.: Изд-во Транспорт, 1968, р. 87.
4. Осенин Ю.И.: *Прогнозирование и управление фрикционными свойствами триботехнической системы «колесо-рельс»*: автореф. дис. ... д. т. н.: 05.22.07. – Восточноукраинский государственный университет. – Луганск, 1994, р. 39.

5. Яворский Б.М., Детлаф А.А.: *Справочник по физике для инженеров и студентов вузов.* – М.: Изд-во «Наука», 1968, р. 940.
6. Кравченко К.О. *Обґрунтування резервів підвищення тягових якостей локомотива та їх реалізація керуванням ковзання в системі колеса з рейкою:* автореф. дис. ... к. т. н.: 05.22.07, Луганск, 2010, р. 23.
7. Фуфрянский Н.А., Долганов А.Н., Нестрахов А.С. и др.: *Развитие локомотивной тяги.* 2–е изд., перераб. и доп. – М.: Транспорт, 1988, р. 344.

Received 17.06.2011; accepted in revised form 19.10.2011