

Turbocharged diesel engine, piston, nonstationary heat flow

Piotr GUSTOF*, **Aleksander HORNIK**

Silesian University of Technology, Faculty of Transport, Department of Vehicle Service
Kraśińskiego St. 8, 40-019 Katowice, Poland

*Corresponding author. E-mail: piotr.gustof@polsl.pl

NONSTATIONARY HEAT FLOW IN THE PISTON OF THE TURBOCHARGED ENGINE

Summary. In this study the numeric computations of nonstationary heat flow in form of temperature distribution on characteristic surfaces of the piston of the turbocharged engine at the beginning phase its work was presented. The computations were performed for fragmentary load engine by means of the two-zone combustion model, the boundary conditions of III kind and the finite elements method (FEM) by using of COSMOS/M program.

NIESTACJONARNY PRZEPIY W CIEPŁA W TŁOKU DOŁADOWANEGO SILNIKA Z ZAPŁONEM SAMOCZYNNYM

Streszczenie. W niniejszej pracy przedstawiono obliczenia numeryczne niestacjonarnego przepływu ciepła w postaci rozkładu temperatury na charakterystycznych powierzchniach tłoka doładowanego silnika z zapłonem samoczynnym w początkowej fazie jego pracy. Obliczenia numeryczne zostały przeprowadzone dla częściowego obciążenia silnika, tj. dla prędkości $n=2000$ [min^{-1}] i współczynnika nadmiaru powietrza $\lambda = 3,08$, przy zastosowaniu dwustrefowego modelu procesu spalania [1], warunków brzegowych III rodzaju oraz metody elementów skończonych (MES), za pomocą programu COSMOS/M.

1. INTRODUCTION

Modeling of nonstationary heat flow in form of temperature distribution in the time of the piston engine was conducted by use of III kind of the boundary conditions. These conditions describe the surface film conductance (fig. 3) as well as the temperature of working medium [2, 3]. The temperature of the working medium (fig. 2) was marked on basis of measured course of the indicated pressure by means of the two-zone of combustion process in the turbocharged Diesel engine (fig. 1). The analysis of the heat loads in the piston engine for the engine speed $n = 2000$ [rpm] for fragmentary engine load which answered the excess air number $\lambda = 3,08$ was carried out. The numeric computations were carried out by use of the finite element method (FEM) in initial phase of the engine work from the moment when the temperature of the piston engine was equal to the ambient temperature at the time in which the temperature distribution in the piston changed in small range.

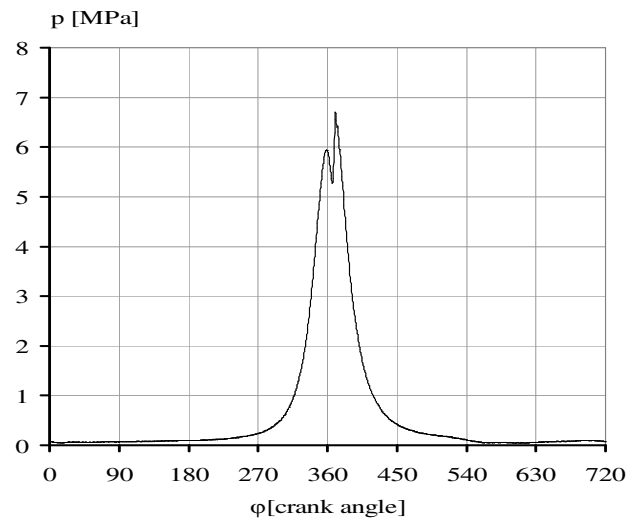

Fig. 1. The diagram of the indicated pressure for engine speed $n=2000$ [rpm] and $\lambda = 3,08$
 Rys. 1. Wykres ciśnienia indykatorowego silnika dla prędkości obrotowej $n=2000$ [min^{-1}] i $\lambda = 3,08$

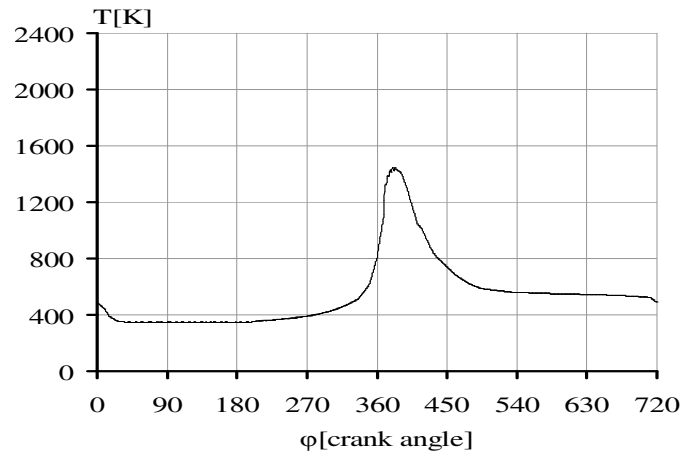

Fig. 2. The diagram of the average combustion temperature for engine speed $n=2000$ [rpm] and $\lambda = 3,08$
 Rys. 2. Wykres średniej temperatury spalania dla prędkości obrotowej $n=2000$ [min^{-1}] i $\lambda = 3,08$

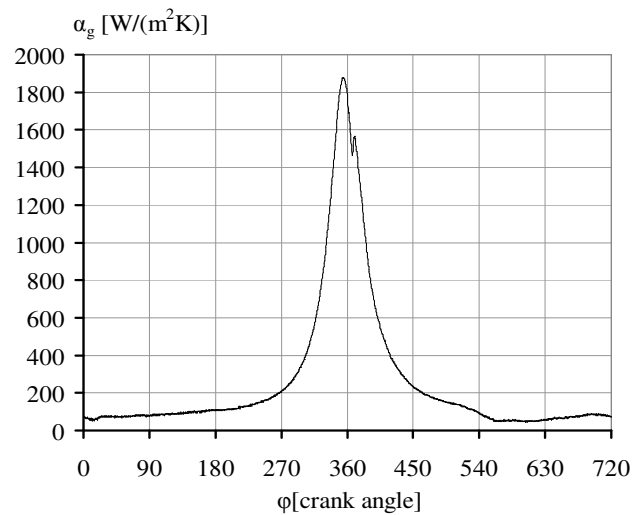

Fig. 3. The diagrams of total surface film conductance for engine speed $n = 2000$ [rpm] and $\lambda = 3,08$
 Rys. 3. Wykres całkowitego współczynnika przejmowania ciepła dla $n=2000$ [min^{-1}] i $\lambda = 3,08$

2. GEOMETRICAL MODEL

The geometrical model of the piston (fig. 4b) was executed with the help of the Geostar computer program COSMOS/M on basis of the real element (fig. 4a). The order of its creation introduced as follows:

- was created the three-dimensional intersection of the piston engine;
- the intersection of the piston was divided with mesh of the finite elements;
- the mesh was based on the three-dimensional elements of tetrahedral solids (tetra 4) about 4 knots and dimensions 1,5 [mm].

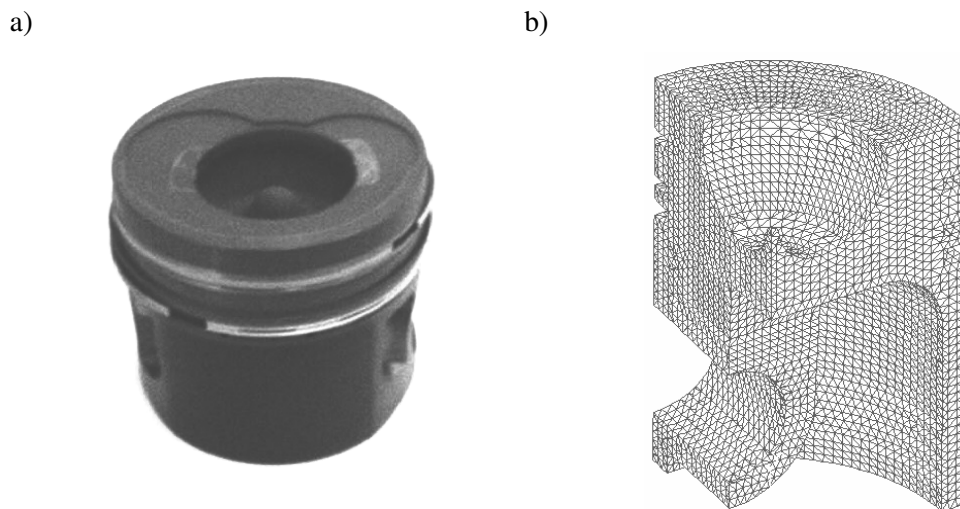

Fig. 4. The piston engine: a) real element , b) discrete model

Rys. 4. Tłok silnika: a) model rzeczywisty, b) model dyskretny

In analyzed the engine piston 16 characteristic surfaces of the heat exchange (fig. 5) were distinguished which define the values of the III kind boundary conditions were attributed [4,5].

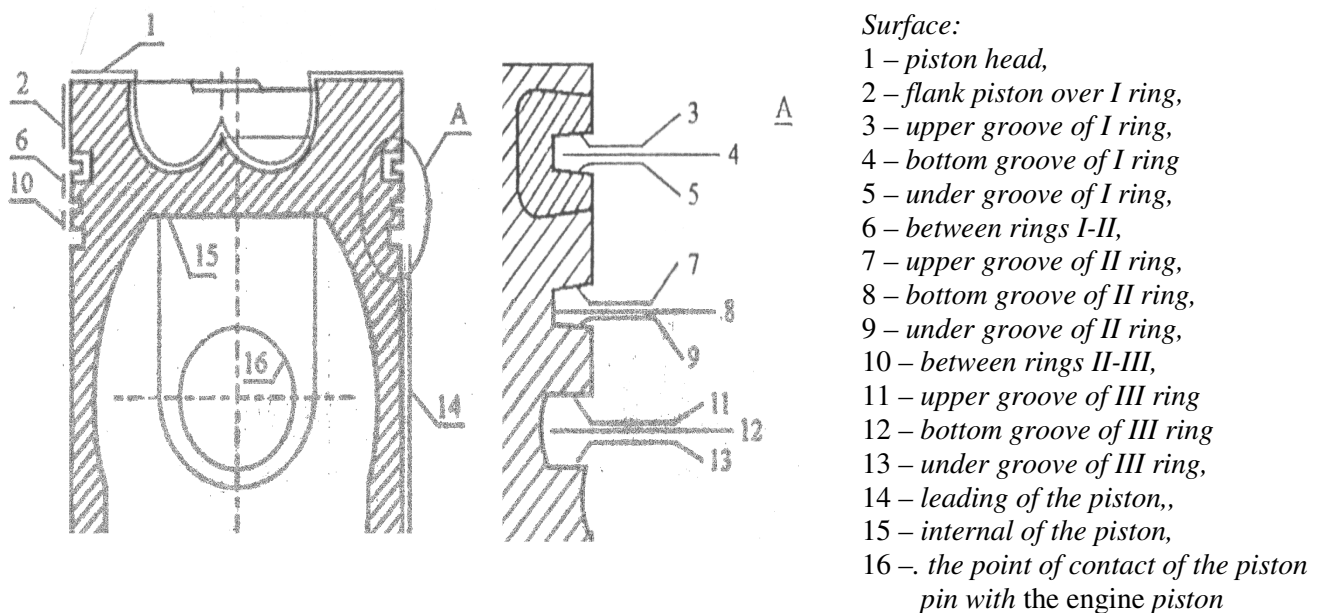

Fig. 5. Surface exchange heat of the piston

Rys. 5. Powierzchnie wymiany ciepła tłoka

3. THE RESULT OF COMPUTATION

In this work the temperature distribution in the piston of turbocharged diesel engine with direct injection about capacity 2390 cm^3 and power rating 85 kW were introduced. Received the numeric computations will be verified on the especially to this aim prepared the engine (fig. 6) which will allow to make the complex research on the measurement station.

The computations were carried out for engine speed $n = 2000 \text{ [rpm]}$ and excess air number $\lambda = 3,08$ for the visualization of the temperature distribution on the piston surfaces for 5 degree of crank angle after inner dead centre of the piston in cycle of filling up engine. The examples results of numeric calculations for 10, 20, 30, 40, 50 and 60 seconds of the engine work were introduced in figure 7.



Fig. 6. Tested turbocharged Diesel engine
Rys. 6. Badany turbodoładowany silnik ZS

After 60 seconds of the engine work the maximum temperature carried out about 410[K]. In the time of warming up of the piston the temperatures were stabilized. The piston head most quickly warmed during first 10 seconds. The average value of the increase speed of the temperature since 0 to 10 [s] for $n=2000 \text{ [rpm]}$ and $\lambda = 3,08$ carried out about 6 [K/s].

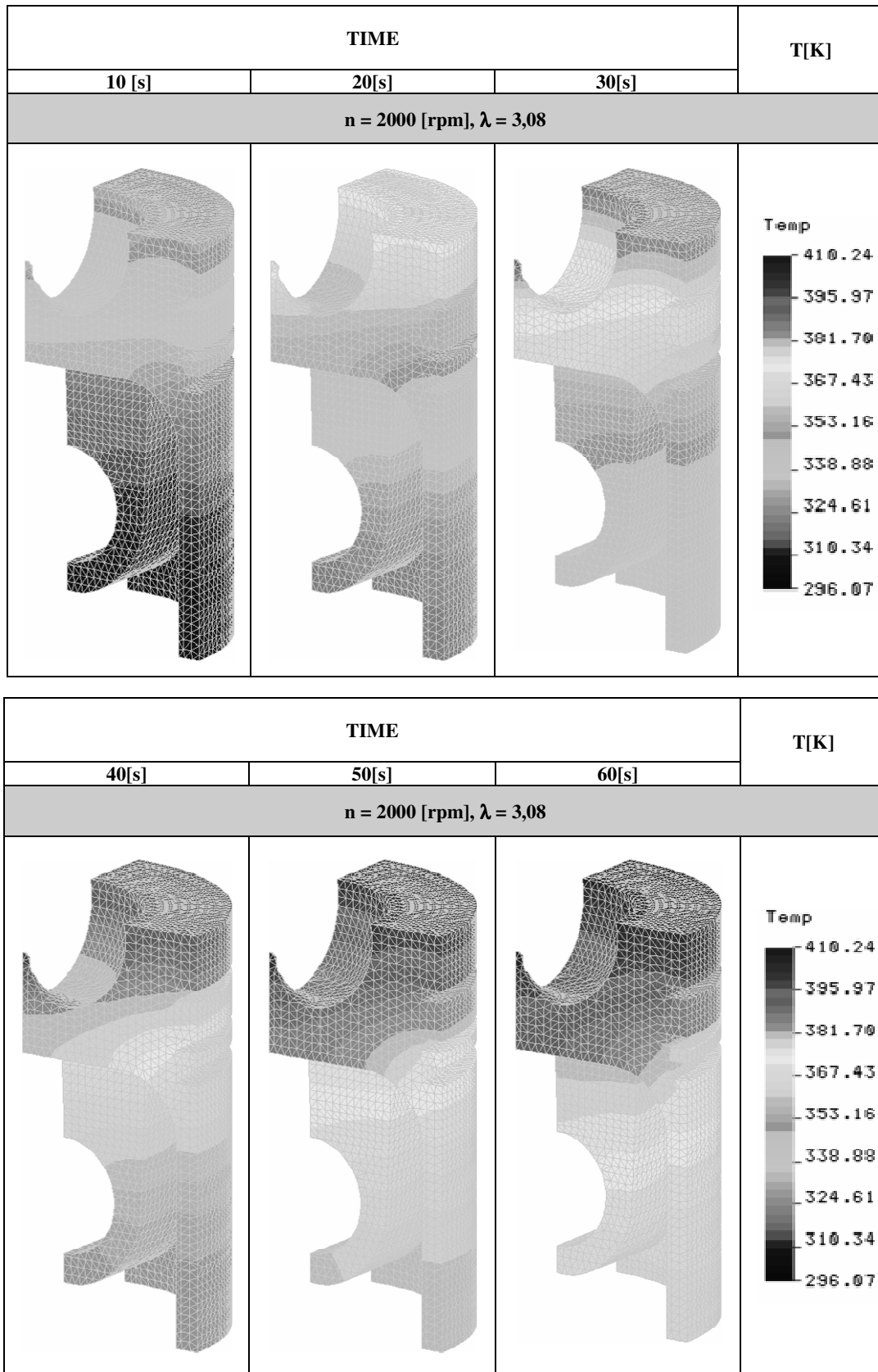

Fig. 7. The following phases of warming up of the piston engine
 Rys. 7. Kolejne fazy nagrzewania się tłoka w czasie

4. CONCLUSIONS

The results of numeric computations of nonstationary heat flow in form of temperature distribution in the piston displayed the possibility of the use of the original two-zone combustion model and finite elements method to analysis of values and temporary temperature distribution on individual surfaces of the piston.

The heat most intensely flows from the surface of the piston head and the flank side above the compression rings into the deep of the piston material. The most intensive warming up of the piston is visible during the first ten seconds of the engine work.

The conducted analysis doesn't permit fully to qualify the heat load of this engine element in regard to short time, the carried out computations however give any picture about the temperature distribution on its individual surfaces. Moreover the correctness of conducted calculations requires on the real piston of the turbo diesel engine use of the verifying researches which will be the object of far more investigations of authors

References

1. Gustof P.: *Wyznaczanie przebiegu temperatur ładunku dla pełnego cyklu roboczego w cylindrze doładowanego silnika o zapłonie samoczynnym*. Zeszyty Naukowe Politechniki Śląskiej, Seria: Transport, z. 43, Gliwice 2001. S. 5-11.
2. Kwaśniewski S., Sroka Z., Zabłocki W.: *Modelowanie obciążeń cieplnych w elementach silników spalinowych*. Oficyna Wydawnicza Politechniki Wrocławskiej, Wrocław 1999.
3. Wiśniewski S.: *Wymiana ciepła*. Państwowe Wydawnictwo Naukowe, Warszawa 1987.
4. Jaskólski J.: *Zagadnienia optymalizacji obciążeń cieplnych tłoków silników spalinowych*. Wydawnictwo Politechniki Częstochowskiej, Częstochowa 2001.
5. Wiśniewski S.: *Obciążenia cieplne silników tłokowych*. Warszawa, WKiŁ, 1972.

Received 18.06.2009; accepted in revised form 02.03.2010