

Tatiana RIPOL'-SARAGOSI

Moscow state university of technology Rostov branch
55, Semashko, Rostov-on-Don, 344007, Russia

Leonid RIPOL'-SARAGOSI

Rostov state university of transport communication
2 Narodnogo Opolcheniya sq., Rostov-on-Don, 344037, Russia

**Corresponding author.* E-mail: leon_raul@mail.ru

**THEORETICAL PRECONDITIONS AND TECHNICAL SUBSTANTIATION
FOR MECHANICAL COMPRESSED AIR DRYING METHOD
APPLICATION ON THE RAILWAY TRANSPORT**

Summary. The article is related to the compressed air purification for the rolling stock problems. The mechanical method is described as a potential way of the compressed air cooling and purifying. The temperature field at the heat conducting surface engineer function equation is given in the article as well.

**ТЕОРЕТИЧЕСКОЕ УСЛОВИЯ И ТЕХНИЧЕСКОЕ ОБОСНОВАНИЕ МЕТОДА
СУШЕНИЯ МЕХАНИЧЕСКИ СЖАТОГО ВОЗДУХА ИСПОЛЬЗУЕМОГО НА
ЖЕЛЕЗНОДОРОЖНОМ ТРАНСПОРТЕ**

Аннотация. В статье освещаются вопросы, относящиеся к осушке сжатого воздуха на подвижном составе. Рассматривается механический метод осушки сжатого воздуха как потенциальный путь его охлаждения и очистки. В статье приведена инженерная формула для расчета поля температур на нагретой теплопроводной поверхности.

Modern and perspective conditions of the railway transportwork and industrial transport locomotives are connected with the motion speed, weight, length of cargo and passenger trains growing.

It is well-known that effective and safe transit organisation is impossible without reliable rolling stock pneumatic system functioning. Largely it determines safety and reliability.

With the first moment railway appearance breaking techniques up today is the one of the most important and responsible rolling-stock elements. Safe railway traffic directly depends on breakings perfection and reliability. In practice different breaches appear in normal functioning, based on the water vapours presence in compressed air. Its condensation under the negative outward air temperatures leads to the breaking mains and apparata freezing what threatens safe railway traffic and leads to locomotive demurrage and financial losses.

What are the basic reasons of the moisture appearance at the breaking mains and apparata, the ice plugs, pneumatic refusals?

All these appearances are called by the compressed air high temperature at the pressure main exceeding outward air temperature. Owing to this compressed air freezes and moisture condenses after the last main reservoir.

The assertion is acknowledged by the many set experiments held on industrial and main rolling-stock [1, 2]. The aforesaid is the acknowledgement of the locomotive pneumatic system cooling surface lack. It has defined the first task for theoretical investigations by the co-workers of the "Automatic breakings" laboratory at the Rostov State University of Transport Communications: gas stream at the cylinder tube mathematical model leading to the engineer counting formula of temperature distribution at the cooling surface function for locomotives with the different geometrical parameters and pneumatic system configuration.

As the initials the basic gas dynamic equations and the corresponding border conditions were used [3].

As the result, for the function T which determines temperature field at the heat conducting surface function, the following expression was received:

$$T = T_* \left\{ \frac{T_{cp}}{T_*} + \frac{r_0}{l} \left[\frac{A_1 C_1}{16} \left(-\frac{r^4}{4} + r^2 \right) \frac{Re(k-1)}{k\rho_{00} \frac{T_{cp}}{T_*}} \varphi'(z) + \left(1 - \frac{3r_0\alpha}{4\lambda} \right) \frac{A_1 C_1}{16} \frac{Re(k-1)}{k\rho_{00} \frac{T_{cp}}{T_*}} \varphi'(z) \frac{\lambda}{r_0\alpha} \right] + (k-1)M^2 \left[\frac{Pr A_1 C_1 r^3}{48\rho_{00}^2} + \frac{\lambda Pr A_1^2 C_1^2}{\rho_{00}^2 r_0 \alpha} \left(\frac{1}{16} - \frac{r_0\alpha}{48\lambda} \right) \right] \right\},$$

where:

$$2C_1 = \frac{P_k^2}{P_*^2} - \frac{P_H^2}{P_*^2}, \tilde{T} = \frac{T_{cp}}{T_*}, \rho_* = \rho_* R T_*;$$

T_* – the character temperature at the investigated point, T_{cp} – average temperature, r_0 – cylinder radius, l – cylinder length,

$$A_1 = \frac{Re}{m^2} \varepsilon;$$

Re – Reynolds number, M – Mach number, $E = (k-1) m^2$, k – Parameter of an adiabatic curve, P_H – the initial pressure at the considered period if time, P_k – the final pressure at the considered period if time, $P_* = \rho_* R T_*$, ρ_* – the characteristic density at the investigated point,

r – the current radius,

$$\rho_{00} = \frac{\varphi(z)}{T_{00}},$$

ρ_{00} , T_{00} – function restriction under $r=0$,

$$\varphi(z) = \sqrt{\left(\frac{P_k^2}{P_H^2} - 1 \right) z + 1},$$

z – function view $\varphi(z)$, α – the heat transfer coefficient, λ – the heat conductivity coefficient for environment, material, Pr – Prandtl number.

The results analysis of the many industrial and main locomotives pneumosystem heat models functioning experiments have shown that out of depending of the outward air temperature and the compressor work mode, the compressed overheating at the last main reservoir exit for the compressor turning off moment is 8 – 10 °C and 6-7 °C for the turning on moment.

Just the compressed air overheating at the way “last main reservoir – engine driver valve” stipulates the moisture condensation and its carrying to the breaking main with following freezing at the environmental negative temperatures [4]. It goes without saying that the cooling surface size for the compressed air to reach the environmental temperature at the last main reservoir exit point under any compressor work modes is obviously insufficiently. In such a way the following investigation task became the extra cooling surface definition with the (1). The extra cooling surface was defined with the algorithm realized by Excel.

The figure 1 gives the extra cooling surface size dependence on the outward air income under the changing compressor mode switching on periodicity from 10 to 50 per cent. The given dependences are constructed for the switching off moment as the most heat intensive mode. The analogue dependence performance for the switching on mode compressor is inexpediently as the less heat mode intensity at the pneumomain. The given dependence analysis shows the maximum extra necessary cooling surface is 11 m².

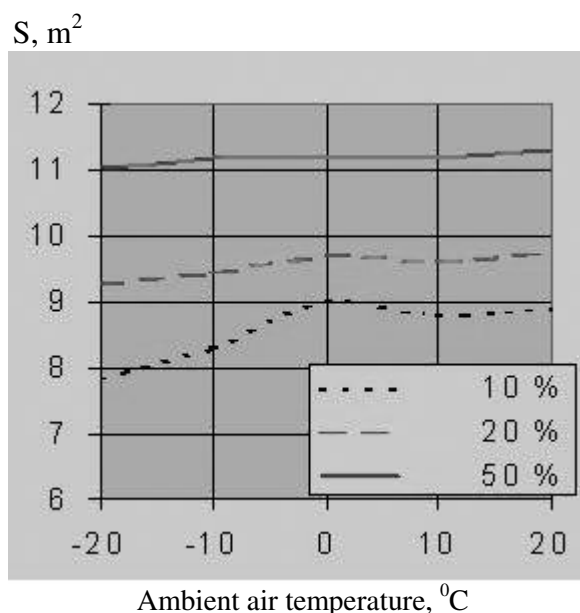

Fig.1. The necessary extra cooling surface size depending on the ambient air temperature at the compressor switching off moment for the periodicity of 10, 20 and 50 %

Рис. 1. Кривые зависимости необходимой дополнительной поверхности охлаждения от температуры окружающей среды, ПВ компрессора на момент выключения 10, 20 и 50 %

For the comfort graphic dependence usage and the received results acknowledgement the construction at the co-ordinate $F=f(t_k \text{ Sw On})$, t_k – the compressed air temperature at the “just after compressor” point.

The necessary cooling surface dependence on “just after compressor” temperature, compressor «Sw On» mode at its turning off moment. At the figure 2 the extra cooling size is determined by the intensity for any of the interested compressor modes at the range of «Sw On» from 5 per cent up to 55 per cent and at the “just after compressor” point the compressed air temperature varies from 0 °C up to 200 °C.

Having taken the decision for the compressed air mechanical drying usage method as the most acceptable for the industrial and main locomotives pneumatic systems the jalousie separators construction for the reservoir application, given at the figure 3a and 3b as basic and modernized construction, was used.

The given construction is patented (2) and has serial inculcation at the DS3 and DE1 cargo-passenger and cargo main locomotives (The Ukraine) and trac agregates (Serie OPE1A and PE2 the Ukraine and PE2M and OP1AM Russia). The built in main reservoir jalousie separator consists of the thin-walled complicated profiles plates. Through their clearances the separated gas goes further. The

device developed surface for the cleaned gas by the separator walls contact is reached by goffered plates package. Small moisture drops at compressed air within the walls contact are condensated on them and as a thin pellicule flow down to moisture drainage system.

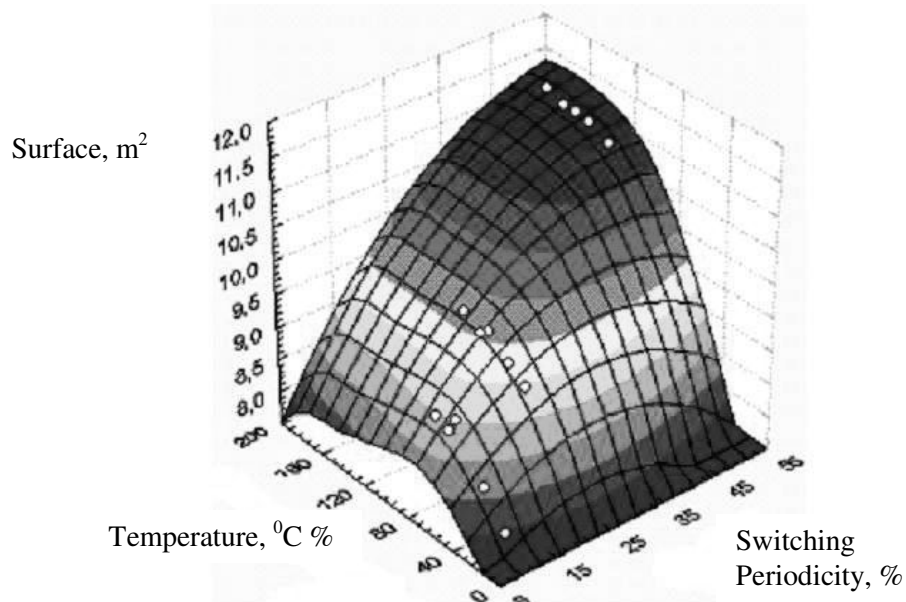

Fig. 2. The necessary extra cooling surface size depending on the “just after compressor point” temperature, Switching Periodicity for the switching off mode

Рис. 2. Потребная дополнительная поверхность охлаждения в зависимости от температуры сжатого воздуха за компрессором, ПВ компрессора на момент его выключения

Compressed air motion at the curvilinear channels calls centrifugal forces promoting moisture drops falling out on the separator surface, as the water wets well steel surfaces the moisture parts contacting the developed surfaces jalousie elements accumulate on them, and then fall down. So got pellicle frustration is possible only under the high compressed air velocity. Compressed air velocity at the main reservoirs does not overcome 0.25 – 0.5 m/sec.

The jalousie separator as a moisture intensifying process device at the main reservoirs choice has allowed to combine a positive properties number:

- small hydraulic resistance;
- reliable heightened velocity decreasing of the local vapour or gas streams;
- compactness.

Thanks to the mentioned above, the jalousie separators industrial usage is practically unlimited. The main reservoir with jalousie separator was inculcated for the first time in world practice at the main locomotives DE1, DS3 and industrial transport locomotives PE1, PE2M, OPEA1A, OPE1AM.

It is supplied by the 11 year positive exploitation experience on the Ukrainian railways and under the open-cast mines of the Russian Federation, the Ukraine and Kazakhstan as well.

The work out criteria of the main reservoirs with the jalousie separators became:

- the objectively necessary effectiveness under the exploitation conditions,
- low resource capacity,
- low energy capacity under the exploitation,
- ergonomics,
- ecological compatibility,
- the outer parameters influence absence on the functioning stability.

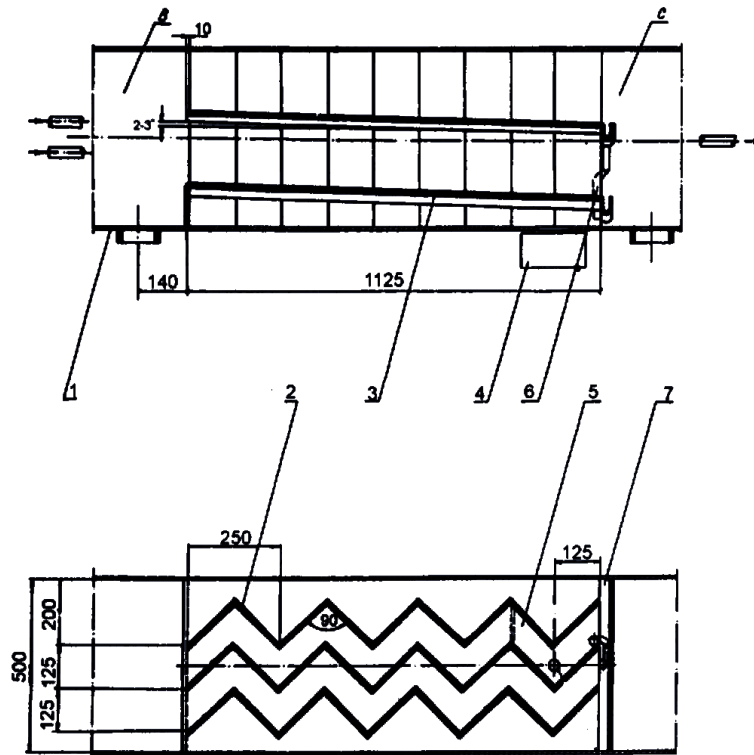

Fig. 3a. The jalousie separator basic construction. B - Wet compressed air chamber, C - dried air chamber, 1 - main reservoir, 2 - goffered plates, 3 - moisture collector, 4 - drainage tube, 5 - drainage trench, 6 - reflector, 7 - hole

Рис. 3а. Базовая конструкция жалюзийного сепаратора. В - камера влажного сжатого воздуха; С - камера сухого сжатого воздуха; 1 - главный резервуар, 2 - гофрированные пластины; 3 - влагосорбник; 4 - дренажная трубка; 5 - дренажный желоб; 6 - отражатель; 7 - прорезь

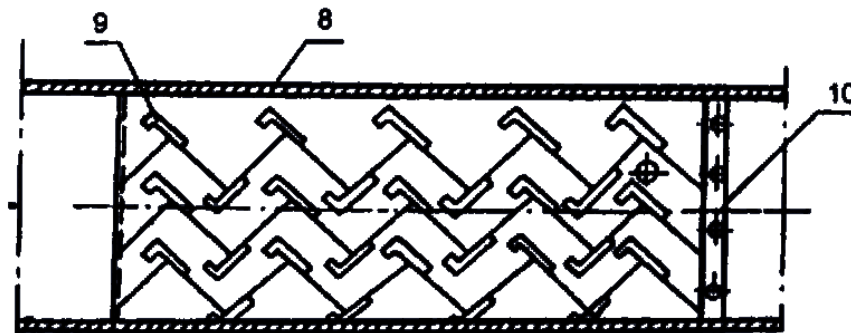

Fig. 3b. The jalousie separator modernized construction. 8 - petals, 9 - reflector, 10 - drainage channel

Рис. 3б. Модернизированный жалюзийный сепаратор. 8 - лепестки, 9 - отражатель, 10 - дренажный канал

The said above allows to make a proposal of the given construction possible introduction enlargement at the railway enterprises such as wagon depot technical service points for instance at the breaks charging and approbation device under the locomotiveless rolling-stock processing compressed air meaning.

References

1. Ripol'-Saragosi T. *Compressed air mechanical dry method application for rolling-stock pneumo-systems wet sedimentation intensification*. The Rostov state university of transport communication bulletin, Rostov-on-Don, 2002, #2, p.42-45.
2. Patent 2192917 Russian Federation, MKI B 6 O 71/00 *Reservoir for wet sedimentation out of compressed gases*. Ripol'-Saragosi T. and others. №. 2001119786; July 16 2001 priority, Bulletin 32, December, 20, 2001.
3. Ripol'-Saragosi T.: *Wet sedimentation intensification managing for rolling-stock pneumo-systems*. Rostov State University poligraphy, Rostov-on-Don, 2001.
4. Balon L., Ripol'-Saragosi T.: *The jalousie separators for main reservoirs*. Locomotive, #10, 2004, p. 6-8.

Received 05.05.2009; accepted in revised form 20.12.2009