

Krzysztof FILIPOWICZ

Silesian University of Technology, Faculty of Mining and Geology,
Institute of Mining Mechanisation
Akademicka 2, 44-100 Gliwice, Poland
Corresponding author. E-mail: krzysztof.filipowicz@polsl.pl

**THE STATIC CHARACTERISTICS OF A TORSIONALLY FLEXIBLE
METAL COUPLING**

Summary. The paper presents a description of test stands and the methodology of determining the static characteristics of a metal coupling of high torsional flexibility. In addition, the paper presents preliminary tests results which enable to determine the above characteristics.

**CHARAKTERYSTYKI STATYCZNE METALOWEGO SPRZĘGŁA
PODATNEGO SKRĘTNIE**

Streszczenie. W pracy przedstawiono budowę nowego rozwiązania konstrukcyjnego metalowego sprzęgła o dużej podatności skrętnej oraz opis stanowisk badawczych i metodykę wyznaczania jego charakterystyk statycznych. Zaprezentowano także uzyskane wstępne wyniki badań, pozwalające na wyznaczenie wymienionych charakterystyk.

1. INTRODUCTION

The conditions of work of power transmission systems used in building, road and mining machines where the transferred torque is in most cases randomly variable require the use of couplings of high torsional flexibility. Such couplings are resistant to specific loads. The proper torsional flexibility may be achieved by means of a solution developed in the Institute of Mining Mechanisation at the Silesian University of Technology. The patented construction of a torsionally flexible metal coupling has been described in literature [2,3,4].

A torsionally flexible coupling is characterised by specific elastic and damping features, which have a basic influence on the performance of the power transmission system due to the change of run and stabilisation of torsional vibration and the load torque. The use of torsionally flexible couplings of unknown characteristics may lead to the incorrect performance of the whole power transmission system. Thus, it is vital to determine the static and dynamic characteristics of torsionally flexible coupling. Such knowledge will ensure the correct work of the power transmission system of the working machine.

The constructive analysis of torsionally flexible couplings, the majority of which has a complex construction and contains flexible connectors of physico-chemical features hard to define, leads to the conclusion that the most proper and advantageous way of determining the characteristics of torsionally flexible couplings is to carry out tests with the use of proper testing stands.

2. RESEARCH AREA

The tests were carried out on one of the constructive proposals of a new, one-directional torsionally flexible metal coupling (Fig.1), where the torque is transmitted from the active to the passive by means of a nut with two screw joints. The screw joints are placed between the externally threaded input shaft (1) and the nut (2), which also has a screw thread on the external cylindrical surface. The external screw thread co-operates with the internal screw thread in the housing (4). Both screw joints have different directions and pitches. The pitches of multiple threads are big enough so that the lead angle is bigger than the friction angle for the screw and nut materials [3, 4].

The resistance of a properly chosen set of disk springs (Fig.1, position 3) and the rotary movement of the input shaft makes the springs press the nut. This leads to the increase of the component of force in the circumferential direction on the screw thread. The increase of this force causes the increase of the torque, and when it reaches the running torque of the machine, its rotary movement, which is at the same time the working movement begins.

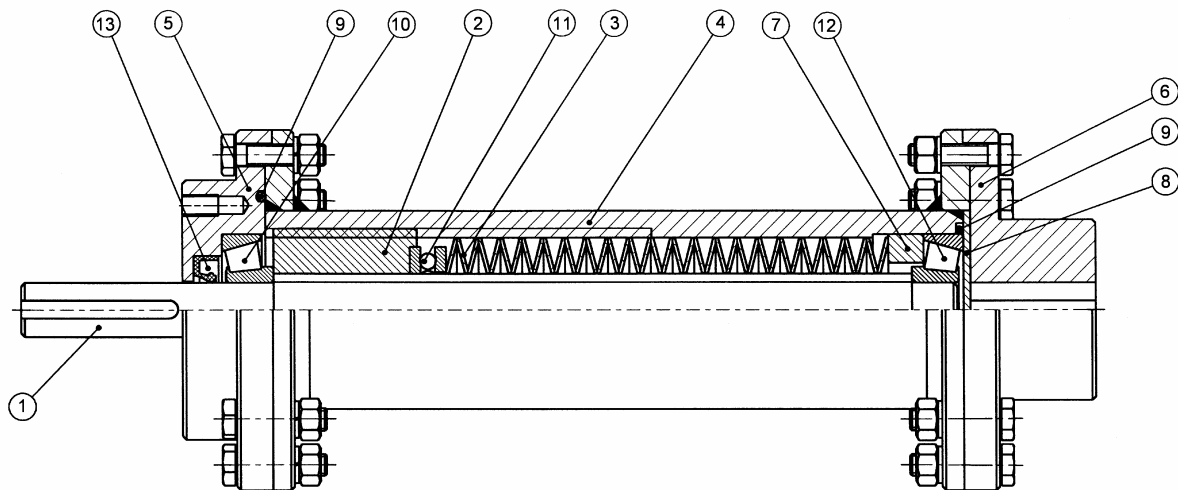

Fig. 1. The prototype of one-way flexible torsional coupling, a – view of the coupling, b – depositional drawing of the coupling, where: 1 – driveshaft, 2 – screw nut with inside and outside thread, 3 – disc springs set, 4 – inner thread housing, 5 – left cover, 6 – output cover, 7 – regulatory ring, 8 – disk sealing up, 9 – seal, 10 – cone bearings, 11 – thrust bearing, 12 – cone bearings, 13 – sealing ring

Rys. 1. Prototyp jednokierunkowego sprzęgła podatnego skrętnie z dwoma gwintami, gdzie: 1 – wał wejściowy, 2 – nakrętka z gwintem wewnętrznym i zewnętrznym, 3 – zespół sprężyn talerzowych, 4 – obudowa z gwintem wewnętrznym, 5 – pokrywa lewa, 6 – piasta wyjściowa, 7 – pierścień regulacyjny, 8 – tarcza uszczelniająca, 9 – uszczelnienia, 10 – łożysko stożkowe, 11 – łożysko wzdłużne, 12 – łożysko stożkowe, 13 – pierścień uszczelniający

Temporary overloads of the working machine causes the additional compression of the elastic elements, and underloads lead to their elastic recovery. When the power transmission system is turned off, the nut pressed by the springs returns to its preliminary position on the input shaft. When the preliminary compression of the nut is big enough and the system has been turned off, the nut returns to its initial position.

The torsional angle of the coupling elements caused by the nominal load between the input and output may be quite significant and reaches e.g. the full turn of the input shaft (active) before the output shaft (passive) begins its rotary motion. The construction of a torsionally flexible metal coupling has been described in previous papers and the patent description [3, 4].

The tests were carried out with the use of couplings with four different sets of disc springs. The choice of these sets was based on the analysis of disc springs characteristics arranged in packs and forming sets. The sets were chosen so that with the maximum torque moment $M_{max} = 100 \text{ Nm}$, the springs would work below the accepted working range, that is 75% of the maximum deflection.

Table 1 contains the data regarding the disc springs used in the coupling and the sets that were placed in it.

Tab. 1

The sets of the disc springs used in the coupling

Coupling Number	Type of disc springs DIN 2093	The number of springs in the pack	The arrangement of the pack
1	40 x 20,4 x 2,5	5	<<<<<>>>>>
2	40 x 20,4 x 2,5	4	<<<<>>>>
3	40 x 20,4 x 2,25	4	<<<<>>>>
4	40 x 20,4 x 2	4	<<<<>>>>

3. DETERMINING THE STATIC CHARACTERISTICS OF THE COUPLING

The static characteristic of a flexible coupling is a dependency of the torque M_{obr} , which turns the coupling by the specific angle of rotation φ between the active and the passive element of the coupling. The changes of the torque in this case should be very slow.

$$M_{obr} = f(\varphi) \quad (1)$$

where: M_{obr} – the torque moment on the flexible coupling, Nm, φ - relative angle of rotation of the coupling elements, radian or degrees.

The shape of the static characteristics depends on the construction of the coupling, the material used for the flexible connecting link i.e. the elastic-damping system and the very shape of the connecting link. In case of couplings with flexible rubber elements or elastomers which are most commonly used in power transmission systems of working machines, the characteristic is nonlinear with damping which makes it hard to choose the proper coupling for the power transmission system [1,5,8].

3.1. The testing stand and methodology of determining the static characteristics of a flexible coupling

The testing stand used to determine the static characteristics of a coupling is used to test the mechanical couplings built in the Institute of Mining Mechanisation at the Silesian University of Technology, as shown in Fig.2.

The electric motor (1) powered by the inverter, which enables the smooth regulation of the rotational speed from $0 \div 1700 \text{ min}^{-1}$, is connected with the tensometric torque meter (5) used to test the torque moment $M_{obr} = M_{stat}$. The value of the measured torque is read and recorded by means of a computerised measuring apparatus (7) of type SCXI produced by National Instruments. One of the elements of the tested flexible metal coupling - the housing (2) is directly attached to the output shaft of the torque meter. The other element of the coupling - the output shaft - is attached to the hydraulic disc brake (3) which is controlled from the pressure supply system (4).

The output shaft of the coupling i.e. the passive element of the coupling is attached to the rotary disc with an angular scale $0^\circ \div 360^\circ$ (6). An indicating needle attached to the coupling housing was used to read the relative angular displacement of the elements $\varphi = \varphi_{stat}$.

When the coupling is secured at the testing stand by means of a fully blocked hydraulic brake, one of the elements of the flexible clutch may no longer turn. The electric motor is activated by means of an inverter and the static torque M_{stat} is gradually increased. The torque moment changes every 10 Nm in order to reach the maximum $M_{max} = 100\text{Nm}$. At the same time the relative angular displacement of the coupling elements φ_{stat} on the angular scale of the disc is read by means of an indicating needle attached to the movable housing. The precision of the reading is $\pm 1^\circ$. The readings of the dependency of the torque M_{stat} on the relative angular displacement φ_{stat} is carried out with and without the load. The aim of this procedure is to determine the hysteresis loop which presents the value of the mechanical energy damping in the coupling.

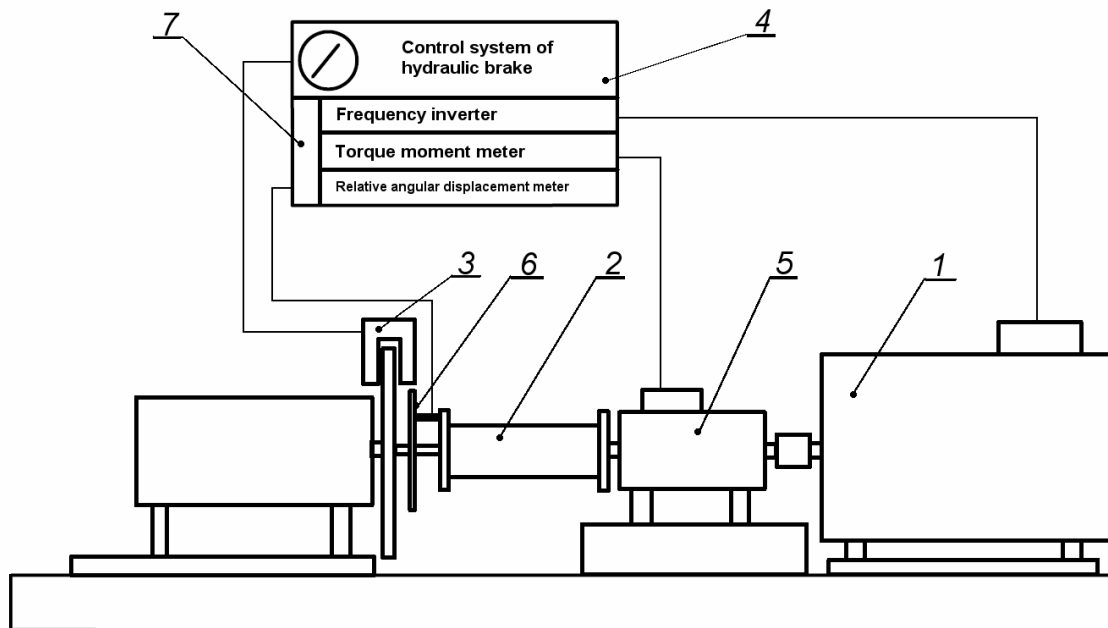

Fig. 2. The testing stand used to test the mechanical couplings, where: 1 – electric motor, 2 – tested flexible coupling, 3 – hydraulic disc brake, 4 – control system of hydraulic brake, 5 – torque meter, 6 – disc with an angular scale, 7 – measuring-recording set

Rys. 2. Stanowisko do badania sprzęgieł mechanicznych, gdzie: 1 – silnik elektryczny, 2 – badane sprzęgło podatne, 3 – tarczowy hamulec hydrauliczny, 4 – układ sterowania hamulcem hydraulicznym, 5 – momentomierz tensometryczny, 6 – tarcza z podziałką kątową, 7 – aparatura pomiarowo-rejestrująca

3.2. The static characteristics of a torsionally flexible metal coupling

The tests enabled to determine the basic static characteristics of the four options of a torsionally flexible metal coupling for spring sets as shown in table 1. Figures 3 are the graphic illustration of the determined static characteristics of different options of the coupling. The determined static characteristics of the torsionally flexible metal coupling are linear with damping of coefficient $r = 0,98$.

When the coupling characteristics are linear as those obtained in the tests, we can determine the coefficient called the torsional rigidity of the coupling k for each of them. For the determined linear static characteristics, the dependency is expressed as follows:

$$k = \frac{M_{stat}}{\varphi_{stat}} \quad (2)$$

where: M_{stat} – the static torque moment on the coupling, Nm φ_{stat} – the corresponding relative angular displacement of the coupling elements, radian or degrees.

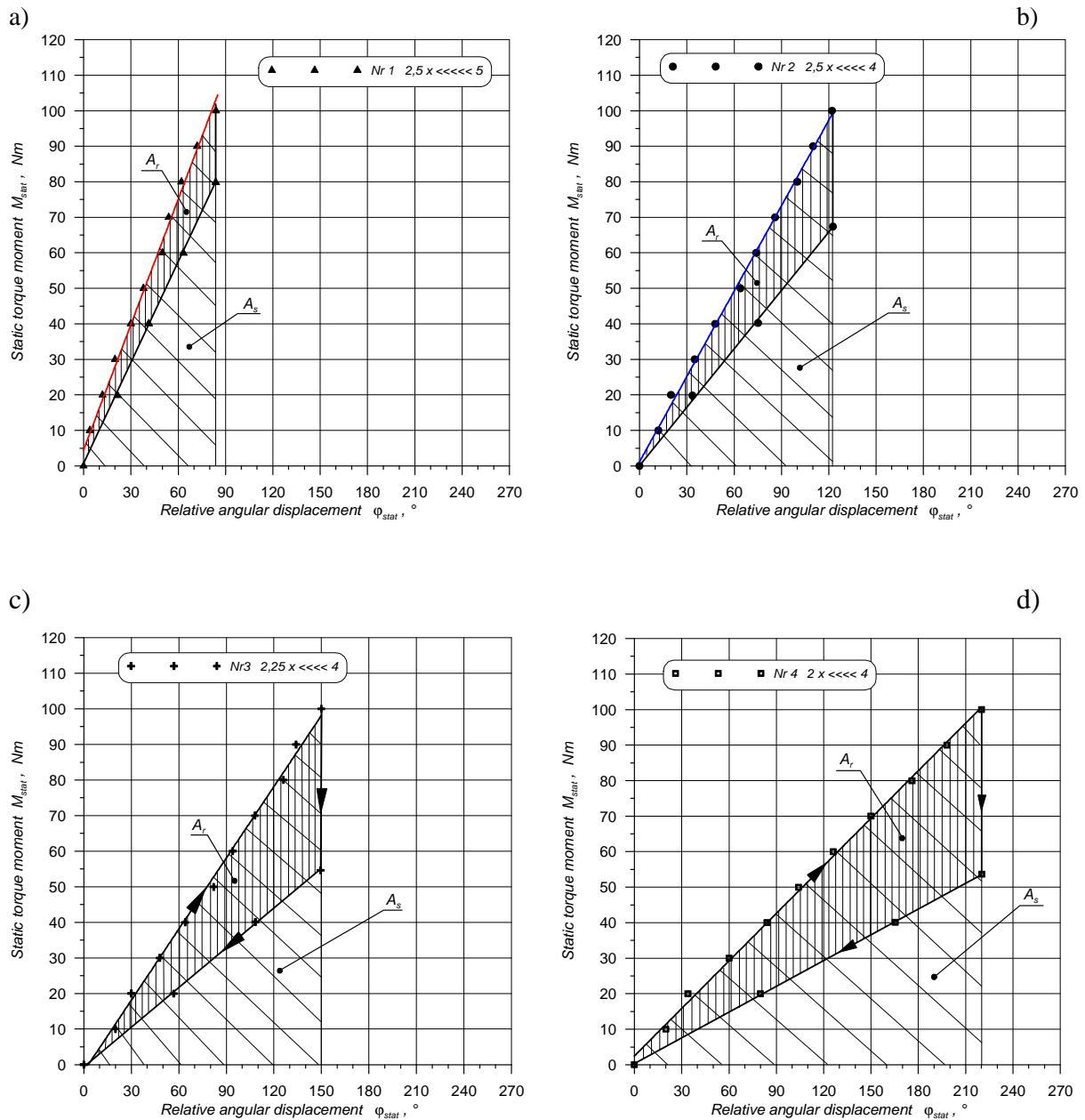

Fig. 3. The illustration of some static characteristics of torsionally flexible metal coupling, where: a – coupling nr 1, b – coupling nr 2, c – coupling nr 3, d – coupling nr 4

Rys. 3. Ilustracja charakterystyk statycznych czterech opcji metalowego sprzęgła podatnego skrętnie, gdzie: a – sprzęgło nr 1, b – sprzęgło nr 2, c – sprzęgło nr 3, d – sprzęgło nr 4

The flexible metal coupling is not only rigid but it also absorbs energy. The hysteresis loop was obtained during loading and unloading and it presented the hysteresis losses of the mechanical energy in the coupling called damping. In the flexible metal coupling damping is achieved by means of constructive friction in screw joints mainly.

The value of the mechanical energy damping in the coupling is specified by the damping coefficient that is determined as follows:

$$\psi = \frac{A_r}{A_s} \tag{3}$$

where: A_r – damping during one working cycle, $\text{Nm} \cdot \text{degrees}$, A_s – elastic strain during one work cycle, $\text{Nm} \cdot \text{degrees}$.

The obtained torsional rigidity coefficients as well as the damping coefficient for the tested options of the torsionally flexible metal clutch are presented in Table 2.

Tab. 2

The obtained torsional rigidity coefficient k and the damping coefficient ψ

Coupling Number	Type of disc springs	The torsional rigidity coefficient k , $\text{Nm}/^\circ$	The damping coefficient ψ
1	40 x 20,4 x 2,5	1,77	0,20
2	40 x 20,4 x 2,5	0,80	0,33
3	40 x 20,4 x 2,25	0,67	0,45
4	40 x 20,4 x 2	0,45	0,47

4. SUMMARY

The preliminary tests carried out to determine the static characteristics of a torsionally flexible metal coupling lead to the following general conclusions:

- The proposed testing stands as well as the methodology of the static characteristics test enable to quickly and correctly determine the static characteristics with acceptable precision and repeatability of the achieved measurements results.
- The determined static characteristics of the torsionally flexible coupling are linear with damping of linear correlation coefficient $r = 0,98$.
- The position and slope of the static characteristics and values of the torsional rigidity and damping coefficients are strictly linked with the application of the disc springs sets in the coupling, the more rigid the springs the greater torsional rigidity of the coupling and the lower the damping coefficient.
- The coupling characteristics can be shaped by the proper choice of disc springs sets, though one has to take into consideration the condition of the proper performance of the spring i.e. up to 75% of its maximum strain.
- The torsionally flexible metal coupling enables to obtain significant angles of the relative angular displacement of the elements even up to a few hundred degrees; the obtained angles are determined by the applied sets of disc springs.

The presented conclusions clearly indicate the advantageous features of the presented constructive solution of the flexible coupling. None of the mechanical couplings which have been used so far in road, building and mining machinery has the above characteristics and the static characteristics as those mentioned above.

Classic flexible couplings enable to obtain angles of mutual torsion only up to a few degrees, in most cases with difficulty to describe nonlinear characteristics.

Bibliography

1. Dietrich M. (red.), Markusik S.: *Podstawy konstrukcji maszyn*. Tom III, wyd. 3. WNT, Warszawa, 1999.
2. Kowal A.: *Sprzęgło mechaniczne*. Patent RP: PL 190945 B1 i PL-191092 B1, 2006.
3. Kowal A.: *Konstrukcja metalowego sprzęgła podatnego skrętnie*. Biblioteka TEMAG. Trwałość Elementów i Węzłów Konstrukcyjnych Maszyn Górniczych, Gliwice-Ustroń, 2005, s.107-116.
4. Kowal A., Filipowicz K.: *Metalowe sprzęgła podatne skrętnie*. Górnictwo i Geologia. T.1, Z.2, Wydawnictwo Politechniki Śląskiej, Gliwice, 2006.
5. Markusik S.: *Sprzęgła mechaniczne*. WNT, Warszawa, 1979.
6. Opasiak T.: *Metody wyznaczania charakterystyk statycznych i dynamicznych sprzęgieł podatnych*. Maszyny Dźwigowo-Transportowe. 2, 2000, s.5-15.
7. Opasiak T.: *Badania charakterystyk statycznych i dynamicznych sprzęgieł nierozłącznych podatnych oponowych*. Praca doktorska, Katowice, 2004.
8. Osiński Z.: *Sprzęgła i hamulce*. PWN, Warszawa, 1985.

Received 17.02.2008; accepted in revised form 22.04.2008