

**Keywords:** railcar; accumulator; energy; simulation; experimental vehicle

**Radovan DOLEČEK\***, Ondřej ČERNÝ, Ladislav MLYNAŘÍK, Petr SÝKORA

Department of Electrical and Electronic Engineering and Signalling in Transport

Jan Perner Transport Faculty, University of Pardubice

Studentská 95, 532 10 Pardubice, Czech Republic

\**Corresponding author.* E-mail: [radovan.dolecek@upce.cz](mailto:radovan.dolecek@upce.cz)

## PASSENGER ACCUMULATOR FED RAILCARS IN REGIONAL RAILWAY TRAFFIC

**Summary.** This paper is focused on contemporary possibilities of replacement diesel-powered railcars by accumulator powered railcars in regional railway traffic. In the first part of the paper, there are described advantages and disadvantages of this replacement. In the second part are presented the simulation counts and the simulation results of the drive of an accumulator powered railcar on the railway line Šumperk - Kouty nad Desnou. At the last part of this paper is shown the experimental accumulator powered railcar, which was built at University of Pardubice, and the energy research, that is realized with this railcar at railway line Mladějov na Moravě - Hřebeč.

## AKKUMULATOR TRIEBWAGENS FÜR REGIONALEISENBahnVERKEHR

**Abstrakt.** Dieses Beitrag ist auf zeitgenössische Möglichkeiten Ersatz Diesel-Triebwagens durch den Akkumulator Triebwagens im Regionaleisenbahnverkehr ausgerichtet. Im ersten Teil des Beitrages gibt es beschriebenen Vorteile und Nachteile dieser Ersatz. Zweiten Teil präsentiert die Simulationen zählt und die Simulation Ergebnisse der Antrieb eines Akkumulators angetrieben Triebwagen auf der Bahnstrecke Šumperk - Kouty nad Desnou. In der letzten Teil dieser Arbeit ist die experimentelle Akkumulator betrieben Triebwagen, die an der Universität Pardubice gebaut wurde, gezeigt und der Energieforschung, dass mit dieser Triebwagen auf Eisenbahnlinie Mladějov na Moravě - Hřebeč realisiert ist.

### 1. ACCUMULATOR POWERED PASSENGER RAILCARS

Electric drives for rolling stock operated in a permanent route have great potential to achieve energy-efficient means of transport. Adapting energy resources, their appropriate dimensioning and optimizing the operating mode can achieve significant energy savings [1 - 6]. Regional passenger rail transport has for a long time been faced with the problem of efficiency. One way to optimize these local transport systems is the usage of accumulator powered rolling stock. This idea is not new - mostly in Germany - there were many accumulators fed passenger railcars successfully operated for many years. But today, they are mostly scrapped, only a few of them are in museums.

What is the reason? The direct costs of such a this rolling stock is significantly lower, than common diesel powered passenger units, and moreover the energy density and power density possibilities of accumulators are today really different, than many years ago. Maybe the inflexibility of the railway operating company is the main reason. But all times increasing costs of diesel and oils are slowly

moving this point of view so some - mostly private - companies are more and more interested in possibilities of accumulator powered passenger units [2, 4, 7, 8].

## 2. TECHNICAL CONDITIONS FOR USAGE OF ACCUMULATOR POWERED PASSENGER RAILCARS

It is rumored, that the crucial part of all accumulator powered vehicles is the accumulator. It seems to be true, but on railway rolling stock it is not such a big problem as on road rolling stock. And electric cars are now mass produced. On the railway passenger unit there is not such a big problem the weight of the accumulator cells - the rail car must have quite a big adhesive weight. For using the accumulators on railway rolling stock is speaking the value of rolling friction – it is about 8-times lower by the steel wheel on the steel rail than by the tire on the road [1, 9, 10]. The dimensions of the cells are no problem as well - it is possible to place them under the main frame in the high-floor vehicles or on the roof on the low-floor vehicles.

Big step ahead in a comparison to common drives is a regenerative braking. Today it is common on modern electric vehicles, on diesel powered vehicles with mechanic, electric or hydrodynamic transmission it is not possible so it will significantly bring less energy consumption. Higher dynamics of a pure electric drive will bring in fact higher cruising speed in comparison to common drives, so it will make the local railway line more competitive.

## 3. SIMULATIONS OF ACCUMULATOR FEEDED TRAFFIC ON RAILWAY LINE ŠUMPERK - KOUTY NAD DESNOU

The reasons written in previous article made us to prepare mathematic model of accumulator fed railcar in real traffic at some local railway line. In the end we chose the line from Šumperk to Kouty nad Desnou in Jeseníky mountains, because it is a privately own line by the municipalities along this line, so it is easier to communicate with this company [8, 11]. The mathematic model includes current timetable, the railway line data and finally the model of the vehicle with its all consumption. One of the results of this simulation is placed on Fig. 1 - it is the graph of energy consumed from the batteries during one journey from Šumperk to Kouty nad Desnou and back. The conclusion of this simulation is, that it is possible to operate this line with accumulator fed passenger unit without any technical problems for a whole day and whole year.

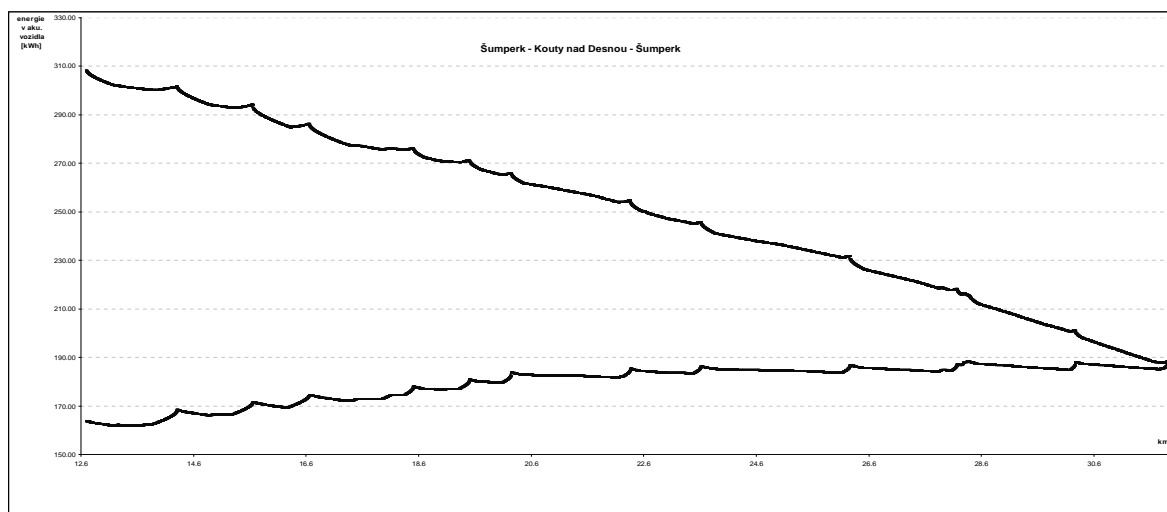

Fig. 1. Traction energy consumption from a mathematical model

Bild 1. Traktionenergieverbrauch aus Mathematisch model

#### 4. EXPERIMENTAL RESEARCH ON EXPERIMENTAL RAILCAR

The simulation persuaded us to do measurement at real railway accumulator powered railcar. Because there is no such vehicle, we made it at the university workshops [11].

##### 4.1. Mechanical construction

The vehicle is designed as a narrow with gauge of 600 mm. Usage of this gauge allows to significantly reducing of building costs, while offering the possibility to use as a test track Mladějov industrial railway. In fact the research of control algorithms for freewheel drive of the tram Škoda 15T was the first reason for building this railcar so further construction of the experimental vehicle has been subordinated in closer to this tram-type or rather one of its bogie. Therefore was selected three-axle design, where is the main element rotating bogie, where are four wheels connected by flexible couplings with four traction motors. The wheel chassis is bound under the main frame, which is partly carried by nonpowered third axle, realized by standard solid wheelset. This undercarriage construction is quite uncommon, but using this experimental railcar is the only way for us, how to do experiments on real railway vehicle. Used wheelset construction allows to compare free rotating wheel drive with classic fix wheelset, which was necessary for previous research project, for energy research it has almost no effect. At the end of the main frame is positioned main electrical switchboard, where is located except traction motors and batteries hanged below the main frame near the third axle all electrical equipment of the vehicle. On the main frame, there is located longitudinal table and on the longitudinal sides the benches for operators. The entire vehicle is then covered with lightweight metal roof.

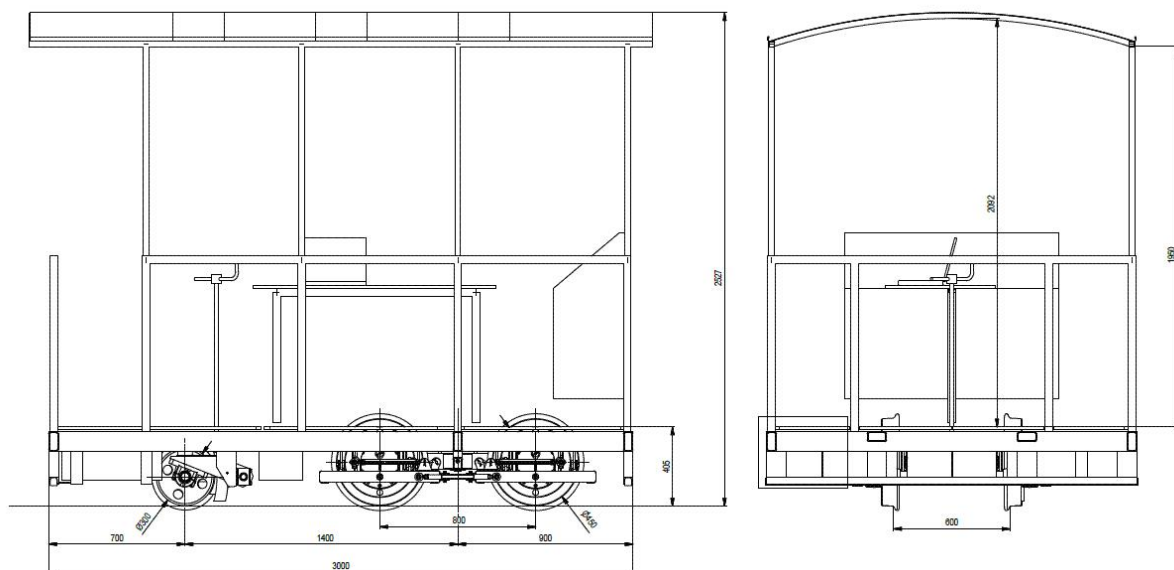

Fig. 2. Mechanical concept of experimental vehicle

Bild 2. Der mechanische Aufbau des Versuchsfahrzeugs

The vehicle is equipped with two independent braking systems. Service brake is electrodynamic regenerative brake. Parking brake and emergency brake is hand screwed construction it is used for third common axle. Whole vehicle is shown in Fig. 3.

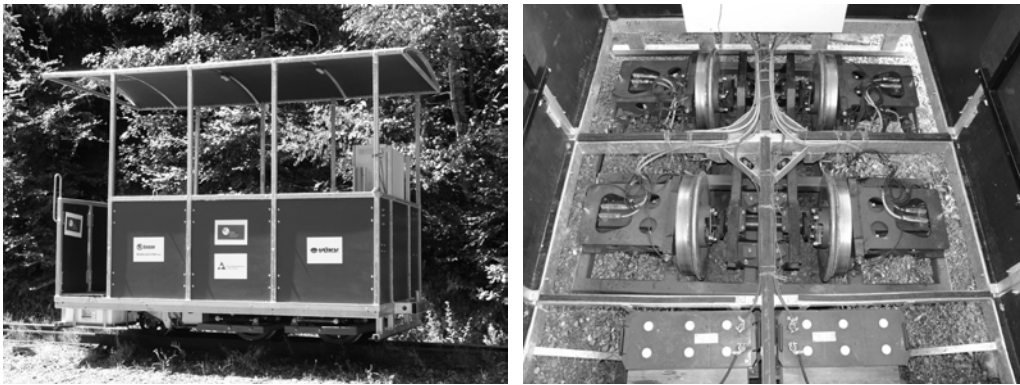

Fig. 3. Experimental vehicle at the railway line and bogie detail  
Bild 3. Experimentelle Fahrzeug an der Eisenbahnlinie und Fahrzeugchassis

## 4.2. Electrical equipment

The vehicle is built as a battery-fed. With regards to traction drive and the estimated consumption of energy was chosen voltage traction battery DC 96 V. This battery voltage is composed of 8 traction lead-acid batteries of the expected capacity of 150 Ah@C5. It was said, that this experimental vehicle was at first built for development of control algorithms of free wheel drive, so there was no impact on battery and energy research – this was the reason of usage of lead acid accumulators, that are quite easy to use and maintain [11 - 14].

The wiring diagram is shown in Fig. 4. TBAT - traction battery is connected to the main breaker Q. It provides both safety disconnection of all electrical equipment from the vehicle battery, and also serves as an emergency switch in case of an accident. For the main circuit breaker is mounted fuse disconnecter F main, staffed 2x 125 A/aM fuses. Followed by a DC bus to which they are connected other circuits. First of all, it is through the circuit breaker FA CH (16 A / C) traction battery charger - the type used AXIstand 96-25 from the firm AXIMA, which is a CPU-controlled fully automatic charger. Power supply of the charger is realized from the normal electric network 3x 400 V ~ / 50 Hz.

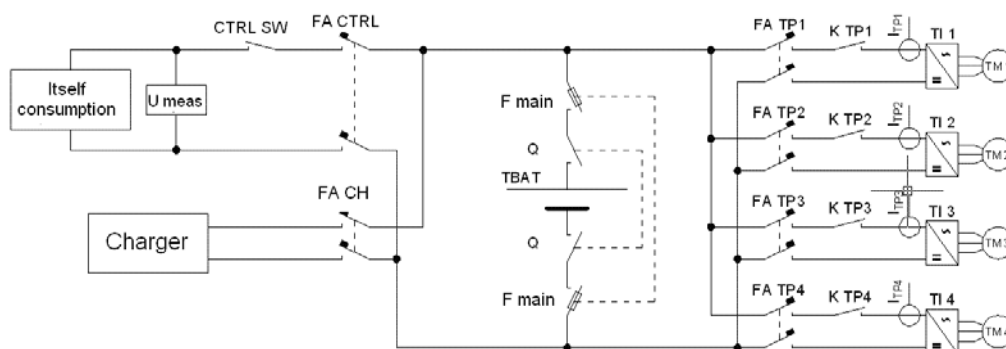

Fig. 4. Simplified diagram of the power circuits of traction electrical equipment  
Bild 4. Vereinfachte Darstellung der Stromkreise der Traktion elektrische Geräte

Furthermore, on the DC bus is connected through a circuit breaker FA CTRL (8 A / C) circuit of its own consumption of the vehicle. Through the said circuit breaker is connected LC filter connected together with DC-DC converters providing non-traction power supply circuits. Through a special circuit breaker is also connected the DC/AC inverter 96 V = / 230 V ~ 50 Hz as a power supply for computers and other devices necessary to ensure test runs.

Finally, the DC bus is connected through a circuit breakers FA TP1 ÷ 4 (25 A / C) into a four traction drives. These are implemented as voltage IGBT inverters. The input capacitors are therefore loaded by auxiliary relays, which are bridged after charging by contactors K 1 ÷ 4. Above the contactors are then placed current sensors ITP 1 ÷ 4. The inverters are built by custom modules from the firm Semikron, type SK 75 GD 066 T. These modules are again over current sensors connected into traction motors type AKM 74P with integrated position sensors.

Management at the level of traction drives is realized through four two-desk regulators Škoda that evaluate the voltage and current waveforms together with the positions of the rotors of traction motors and calculate individual power-switching of transistors. Connection between regulators and transistors is realized by a compact driver Semikron SKHI 61.

The modular control system Compact RIO from the firm National Instruments is used as a master controller. This system provides due to its modularity imposed requirements, but also is robust enough for use on rolling stock. Its other advantage is its programming in LabView graphical language, resulting in very efficient and intuitive creation of control algorithms including their ease of modification, this system is also used to collect data during the test runs. The structure of the control system of the vehicle is shown in Fig. 5, [2].

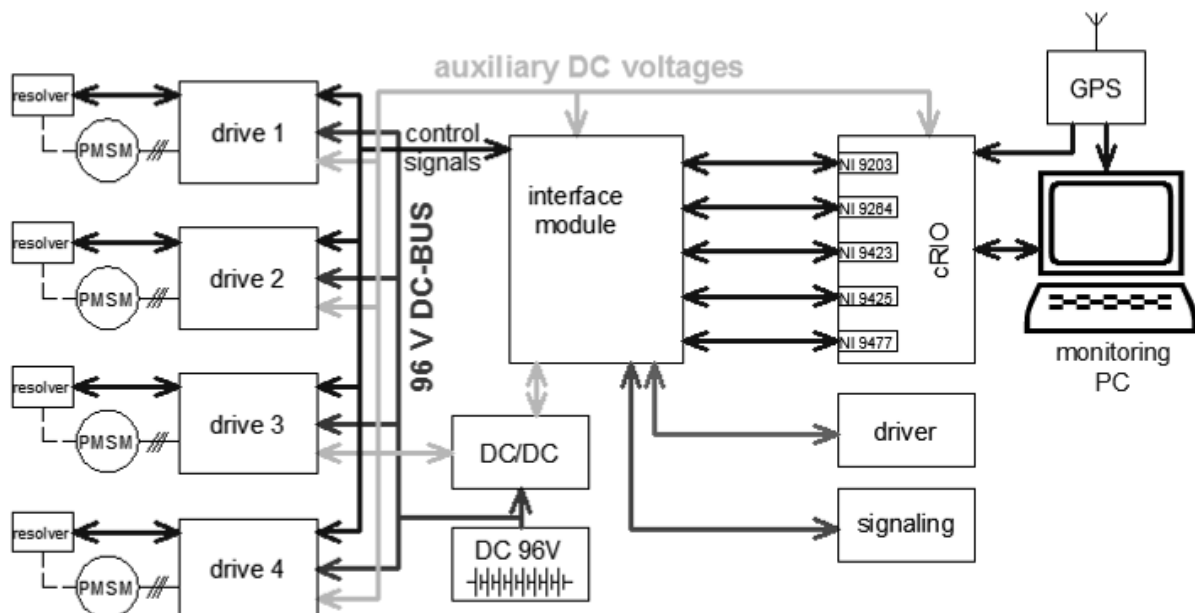

Fig. 5. Simplified diagram of the control system of a vehicle  
Bild 5. Vereinfachtes Schaltbild des Steuersystems des Fahrzeugs

### 4.3. Mladějov Industrial Railway

Mladějov industrial railway is 11 km long narrow track railway with the gauge 600 mm, it is situated at the border of Czech and Moravia between Česká Třebová and Moravská Třebová. It was built during the 1st. world war to transport coal and fireclay from the mines at Hřebeč mountains to the factory at Mladějov na Moravě. The first part of the line - about 2.8 km long - has elevation about 30 per miles up from Mladějov factory, next 4 km are quite flat, rest of the line is in elevation about 5 per miles. In whole length of the line, there are many curves with low diameters.

Until 1991 this railway was daily operated with original steam locomotives (!) to transport the fireclay from the mines at Hřebeč to Mladějov factory, then were both the mines and the factory closed. Few years ago, volunteers started operation of tourist trains during the weekends in the spring, summer and autumn, this operation scheme is used until this day. So during the workdays there are

generally no trains at the line, it is possible to use it as an experimental base for measuring with the experimental railcar that was built at University of Pardubice. The gauge of this railway, low speed and many curves has probably influence on measured values - mainly according to low speed, because of unimportant influence of aerodynamic drag, but traction mechanics should govern generally on every rail traffic, so they could be recounted to normal gauge vehicle.

#### 4.4. Experimental research at railway line Mladějov - Hřebeč

The research is now focused mainly for the freewheel drive control, but there were done some energy measurements too, mainly on the part from Mladějov to Nová Ves station and back, so from km 0.0 to 6.8 and back. The measured values of speed, power, DC bus voltage and battery current and finally of the consumed energy are – all depending on time – listed in Fig. 6. - 10.

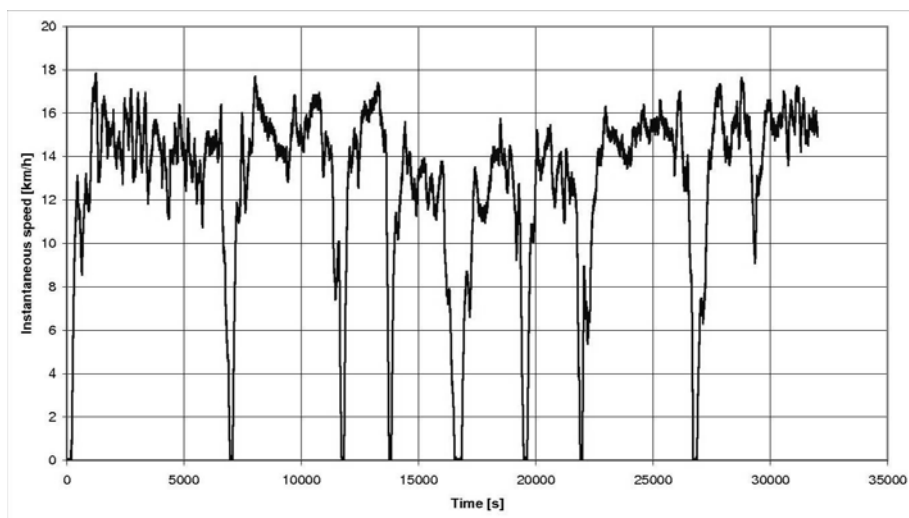

Fig. 6. Vehicle speed  
Bild 6. Geschwindigkeit des Fahrzeuges

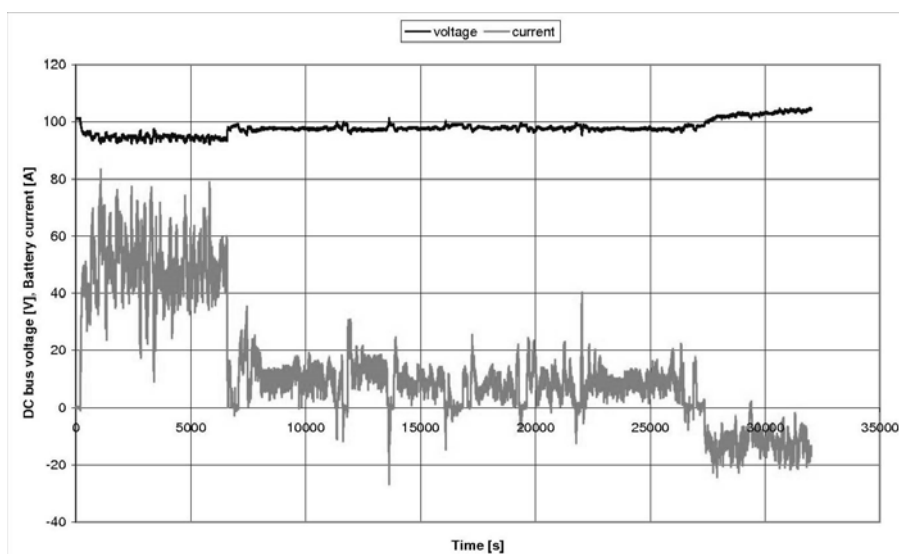

Fig. 7. DC bus voltage and battery current  
Bild 7. Gleichstromhauptleitung Spannung und Batterie Strom

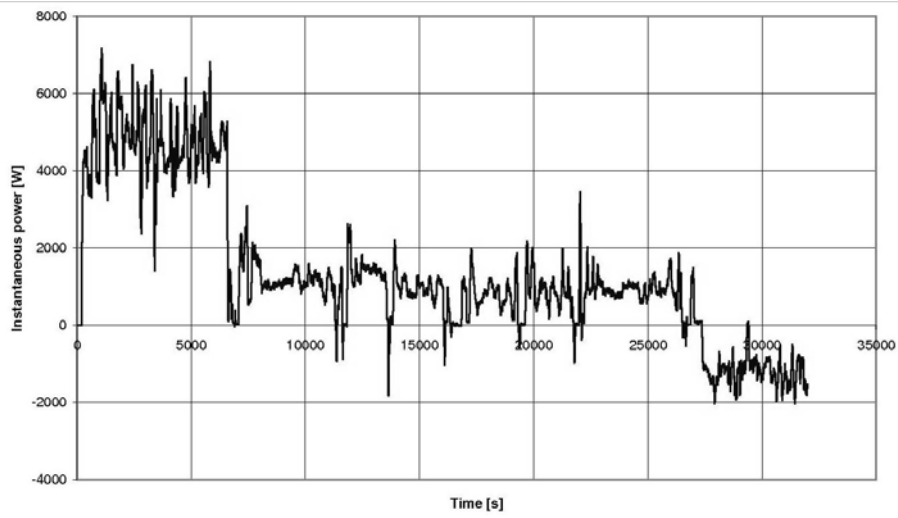

Fig. 8. Traction power  
Bild 8. Traktion Leistung

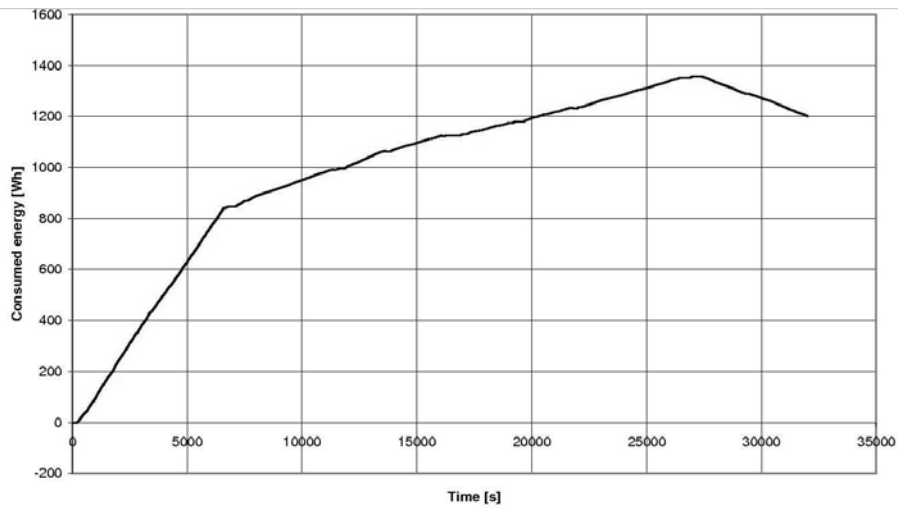

Fig. 9. Energy cosumed from the battery  
Bild 9. Traktionenergieverbrauch

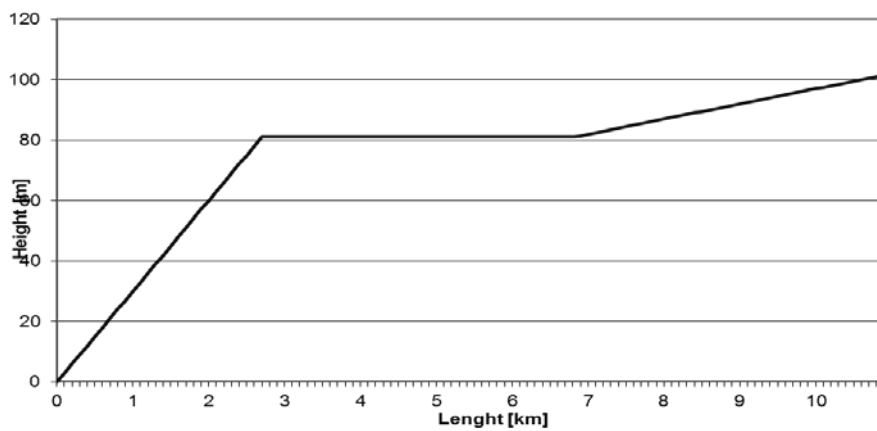

Fig. 10. Altitude profile tracks  
Bild 10. Höhenprofil Bahnen

## 5. CONCLUSIONS

The simulations shows, that it is from a technical point of view possible to operate some railway by the accumulator fed electric railcar. The experiment shows the same – with the model we proved, that it is possible to use accumulator feeding for passenger railcar and the final energy consumption is quite low - the energy consumption for a one journey from Mladějov to Nová Ves in the middle of the line and back is about 1.2 kWh – by the charging of the accumulators it could be about 2 kWh, it is about 10 CZK (0.36 €). The smallest rail cycle used at Mladějov industrial railway with the same weight about 2 tons consume about 3 liters of diesel fuel for the same duty, so it is about 100 CZK (3.60 €). It means that the accumulator traffic is very cheap for direct costs. The issue of indirect costs is in rolling stock very difficult, because of long terms of financial depreciations and public support of passenger traffic, so we did not count these costs. It seems, that it is not possible to build and operate new railway vehicles with accumulator feeding without this support, but the energy and traffic policy of EU for next years scheduled to reduce fossil fuel using so - maybe - the European funds could help to roll out this kind of vehicles into from experiments to mass usage. Big influence will have each state energy and traffic policy too.

For the fix costs it is not so optimistic. The producers of the rolling stock are not building the accumulator vehicles as a mass production like a diesel power locomotives and passenger units, so the construction of them will be very, very expensive. But this investment will be done for many years forward and for whole lifecycle of the railcar, so it won't be so strange in the end. We hope, that some operator will risk it and will build or buy normal gauge accumulator railcar and start to operate it in common traffic but it seems, it will take really a long time.

In our research, we are going to change the lead acid batteries by lithium batteries and to compare these two technologies from the point of view of energy. We are going to do more simulations and experiments too, at first in the area of mapping the energy floats by charging of accumulators and by driving the vehicle. Then we want to do optimizations of the drive of the experimental railcar in the railway line - it should further decrease energy consumption. In the end, we want to use as an energy resource for charging the traction accumulators solar cells, because it seems, that it will be possible to charge it for every day use by the cells on the roof of the vehicle and on the roof of the locomotive shed.

## Acknowledgment

The research is supported by the Technology Agency of the Czech Republic under the grant No. TE01020038.

## References

1. Tsukahara, K. & Kondo, K. A study on methods to design and select energy storage devices for Fuel Cell hybrid powered railway vehicles, In: *Industrial Electronics Society, IECON 2013*. Vienna. 2013. P. 4534-4539.
2. Mayet, C. & Bouscayrol, A. & Pouget, J. & Lhomme, W. & Letrouve, T. Different models of an energy storage subsystem for a hybrid locomotive, In: *Power Electronics and Applications*. Lille. 2013. P. 1-10.
3. Steiner, M. & Klohr, M. & Pagiela, S. Energy storage system with ultracaps on board of railway vehicles, In: *Power Electronics and Applications*. Aalborg. 2007. P. 1-10.
4. Akli, C.R. & Roboam, X. & Sareni, B. & Jeunesse, A., Energy management and sizing of a hybrid locomotive, In: *Power Electronics and Applications*. Aalborg. 2007. P. 1-10.
5. Bowkett, M. & Thanapalan, K. & Stockley, T. & Hathway, M. & Williams, J. Design and implementation of an optimal battery management system for hybrid electric vehicles, In: *Automation and Computing*. London. 2013. P. 1-5.



6. Chuan sheng Si, Development research about the power battery management system of pure electric vehicle, In: *Consumer Electronics, Communications and Networks*. XianNing. 2011. P. 276-279.
7. Hoimoja, H. & Roasto, I. & Keskkula, A. Design concepts for a hybrid diesel electric shunting locomotive powertrain. In: *Electronics Conference*. Tallinn. 2010. P. 293-296.
8. Halme, J. & Suomela, J. Optimal efficiency based Gen-set control for series hybrid work machine, In: *Vehicle Power and Propulsion Conference*. Seoul. 2012. P. 836-839.
9. Zhang, X.S. & Yuan, Y. & Sun, C.C. & Wang, M. & Fu, Z.X. Optimal electric vehicle charging schedule based on minimum marginal energy production cost. In: *Renewable Power Generation Conference (RPG 2013), 2nd IET*. Beijing. 2013. P. 1-4.
10. Chengzong, P. & Aravinthan, V. & Xiaoyun, W. Electric vehicles as configurable distributed energy storage in the smart grid. In: *Power Systems Conference (PSC)*. Clemson. 2014. P. 1-4.
11. Agenjos, E. & Gabaldon, A. & Franco, F. G. & Molina, R. & Valero, S. & Ortiz, M. Energy efficiency in railways: Energy storage and electric generation in diesel electric locomotives. In: *CIREN 2009, „Electricity Distribution - Part 1“*. 2009. P. 1-7.
12. Šimánek, J. & Novák, J. & Černý, O. & Doleček, R. FOC and flux weakening for traction drive with permanent magnet synchronous motor, In: *Proceedings of International Conference Proceedings of IEEE International Symposium on Industrial Electronics*. United Kingdom, 2008. P. 753-758.
13. Doleček, R. & Černý, O. & Němec, Z. EMC of traction drive with permanent magnet synchronous motor, In: *Proceedings of International Conference Proceedings of International Conference on Electromagnetics in Advanced Applications*. Torino – Italy. 2009. P. 1-4.
14. Baert, J. & Jemei, S. & Chamagne, D. & Hissel, D. Energetic macroscopic representation of a hybrid electric locomotive and experimental characterization of Nickel-Cadmium battery cells. In: *Power Electronics and Applications (EPE)*. Lille. 2013. P. 1-10.

Received 27.08.2013; accepted in revised form 21.04.2015