

passive safety; vehicle body; collision; deceleration; plastic deformation

Damian HADRYŚ*, **Michał MIROS**

Higher School of Labour Safety Management
Bankowa st. 8, 40-007 Katowice, Poland

Tomasz WĘGRZYN

Silesian University of Technology, Faculty of Transport
Kraśińskiego st. 8, 40-019 Katowice, Poland

Abilio Manuel Pereira da SILVA

University of Beira Interior, Electromechanical Department
Edifício 1 Engenharias, 6200-001 Covilha, Portugal

*Corresponding author. E-mail: dhadrys@wszop.edu.pl

DRIVER SAFETY IN RELATION TO THE POST-ACCIDENT VEHICLE REPARATION

Summary. The paper presents the basic criteria for estimation of the post-accident reparation of a vehicle body. The article made reference to deceleration during an impact, to deformation of the vehicle body (as a result of a collision) and to the coefficient of restitution that describes such a collision.

BEZPIECZEŃSTWO KIEROWCY W RELACJI DO NAPRAWY POWYPADKOWEJ POJAZDU

Streszczenie. W artykule przedstawiono podstawowe kryteria pozwalające na ocenę powypadkowej naprawy nadwozia pojazdu. Odniesiono się do wartości opóźnienia podczas zderzenia, deformacji nadwozia w wyniku zderzenia i wartości współczynnika restytucji, opisującego zderzenie.

1. INTRODUCTION

By 2020 it will have been observed a very large increase in the transport demands. It is directly related to the expected high economic growth and to a significant increase in international trade. The main predictions of the growing demand for transport by 2020 are the following:

- a large increase in the intensity of the road transport about 2,5% per year, at a high volume of traffic it is about 993 million tonnes of transported cargoes per year,
- the massive increase in the demand for the road transport of international trade (an increase about 300%),
- a growing number of airline passengers about 175%,
- an increase in cargo handling in Baltic sea ports about 60%,
- an increase in the number of passenger vehicle about 60%.

A vehicle driver is a very popular profession that is considered to be dangerous. Given that the professional driver spends many hours daily in the vehicle (very often being under stress) this professional requires good and safe conditions. Professional driver can be under stress because of: traffic noise, rush hour traffic, being stuck in heavy traffic, traffic congestions, weather conditions,

other drivers, etc. In Poland about 15 people are killed every day and about 5570 people are killed in road accidents every year. One of the reasons of such a situation is a poor condition of cars in Poland. In comparison to other countries in the European Union, the cars on Polish roads are much older (an average car age is about 14 years). For example, an average vehicle age in Portugal is 10 years and the number of fatal traffic accidents is 900 people per year. In Portugal, it is twice accidents less per 100 000 habitants.

In view of the fact that the car age in Poland is about 40% higher than in Portugal it seems to be natural that the technical condition of the vehicle in Poland is respectively worse. This situation causes that more repairs of the vehicles after accidents is required. In Portugal, for example a vehicle after a road accident is mostly scrapped while in Poland is repaired and still in use. Additionally, the main problem is that many of the seriously damaged vehicles in the other countries are often illegally imported to Poland, then repaired and used. These facts influence in some way on a big rise in the number of accidents and over the safety of the vehicle drivers.

Taking the vehicle driver's safety into consideration (a taxi driver, ambulance, courier, truck driver and so on) the technical condition of the vehicle, especially after a post-accident repairs is the most important issue.

In order to determine that all accidental damages to the vehicle were done correctly it needs estimating whether repairs was done correctly. This might base on the various automotive criteria.

2. THE BASIC AUTOMOTIVE CRITERIA

The basic automotive criteria should be defined in order to assess the accuracy of the post-accident reparation of damaged vehicle body. The following criteria are proposed below:

- geometry of the vehicle body after the post-accident repairs,
- the aesthetic appearance of the vehicle body after the repairs,
- a level of vehicle deceleration during the next collision,
- deformation of the vehicle body during the next collision,
- the coefficient of restitution in case of next collision,
- permissible stress of the vehicle body after repairs.

The first and second of the given criteria aren't the destructive tests. The post-accident repairs have been done correctly taking into consideration the criterion of the vehicle body geometry. In that case the location of the base points of the vehicle is compared with the data of a vehicle manufacturer. The fig. 1 and 2 [1] show the test cards for testing the position of the basis points of a vehicle body of Fiat Punto.

Actually, the post-accident repairs are done using modern equipment. It is possible to observe in real time the coordinates of the base points for easy measurement. This enables to assess of compliance with the criterion of car body geometry. Advantage of these kinds of measurements is that they may be done during or after the repairs. The second criterion for the appearance of the vehicle body after the post-repairs does not require destructive test. This criterion does not influence on safety of vehicle after post-accident repairs.

Another of the automotive criterion needs to do destructive tests in order to evaluate if the post-accident repairs was done correctly. There are two kinds of those automotive tests. The first one concerns the whole repaired vehicle. The second one concerns only the repaired part of the vehicle. These kind of researches requires to destroy the vehicle body and therefore they are not used in practice. An interesting alternative to the mentioned tests is an idea of constructing the model elements instead of destroying the vehicle. That model has the advantage of lowering the cost of these researches. In that case all the tests are conducted on the model element of the vehicle body. These tests should make it easier to determine the level of decision-making in order to properly evaluate the correctness and effectiveness of the post-accident repairs of the vehicle body. The third automotive criterion is the deceleration course of a vehicle during collision. It assumes that the value of the deceleration of the vehicle can not be greater after the crash. Deformation of the repaired car body during the next collision should not be greater than deformation of this vehicle body from the initial

collision. The criterion for coefficient of restitution assumes the same value of this parameter for all collisions. This ratio describes the extent to which the collision has the plastic or elastic deformation character. The low coefficient of restitution means that most of the collision energy is used for the permanent deformation of the vehicle body. Thus, if the coefficient of restitution is greater, the permanent deformation of the vehicle body will be smaller. It is associated with an increase in the value of deceleration during car impact. On the basis of the information given above it can be concluded that there are the particular relationships between the various criteria and between the different values that describe the collision. Permissible stress of the repaired parts shouldn't be less than before the collision. This means that after the repairs the vehicle body should be in good working order (such as before the collision). Permissible stress of repaired parts of the vehicle body must be larger than stress of the same automotive elements before the collision. If the permissible stress is the same or larger after the repair during the next collision, the maximum value of deceleration, body deformation and the coefficient of restitution will be also the same.

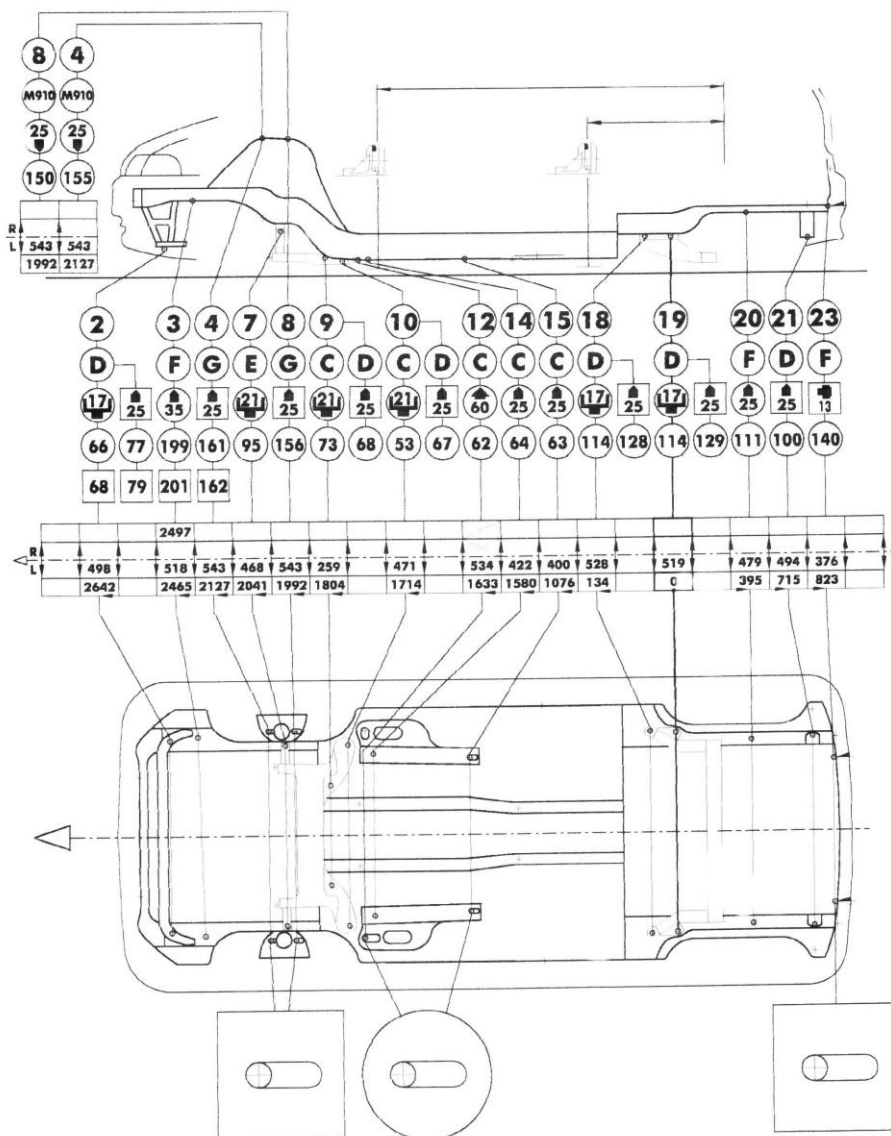

Fig. 1. Data for determining the position of the basis points of Fiat Punto floor panel
 Rys. 1. Dane dotyczące rozmieszczenia punktów bazowych w płycie podłogowej Fiata Punto

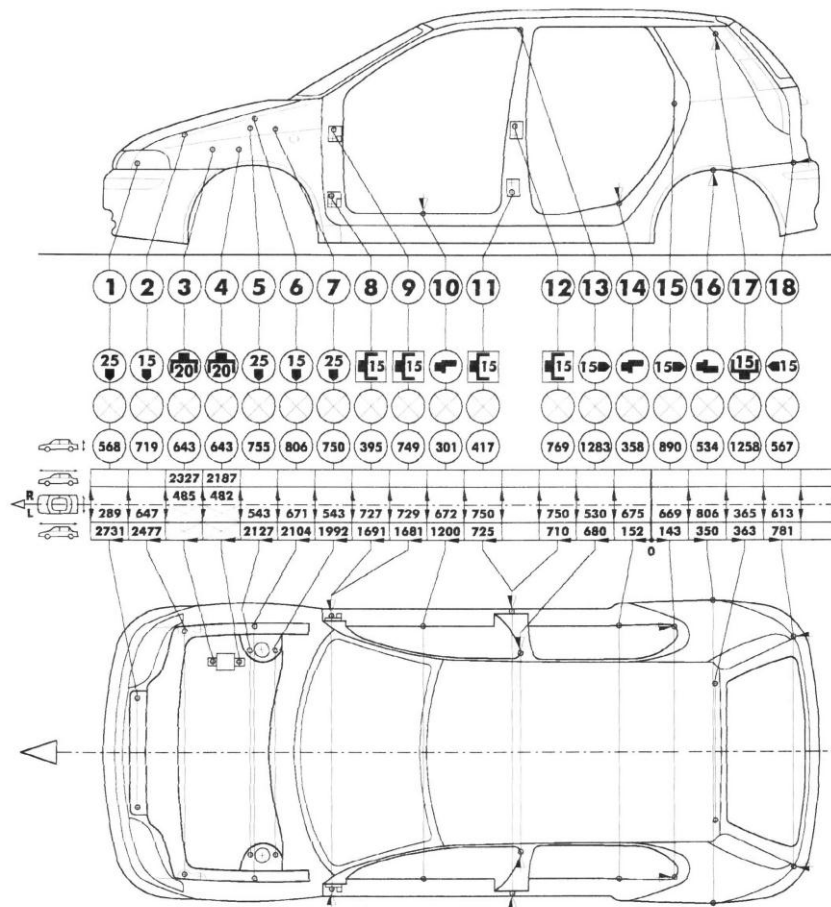

Fig. 2. Data for determining the position of the basis points of the upper part of Fiat Punto body
Rys. 2. Dane dotyczące rozmieszczenia punktów bazowych w górnych partiach nadwozia Fiata Punto

If the permissible stress the repaired item is smaller in relation to the element before the collision, for the next collision the maximum value of the deceleration will be respectively smaller, body deformation will increase and the coefficient of restitution will be lower. It is beneficial to have reduction of the deceleration however incensement of the deformation of the body must be treated as a disadvantage. If the permissible stress of the repaired component is greater after the collision, then for the next collision the maximum value of the deceleration and the coefficient of restitution will be higher and the car body deformation will be less. In that case it is disadvantageous to increase the deceleration, but it is preferred to reduce the deformation of the vehicle body.

There is one more limitation, namely load and stress limits for the repaired element can not be very high. The following example (fig. 2 to 4) explains how to determine extreme values of allowable stress for the repaired elements, so as to deceleration and deformation of the vehicle body was at an acceptable level.

A fig. 2 graphically shows relation of material stress as a function of time $\sigma_0=f(t)$, $\sigma=f(t)$, $\sigma_M=f(t)$ and $\sigma_{MA}=f(t)$. Material stress σ is marked as the maximum of allowable stress for the item during its normal operation. The value of that stress decreases with time. Stress is variable with time, but an average value σ_M may be determined. For a moment t_0 σ_M the value of stress value increases rapidly above the allowable instantaneous value of stress $\sigma(t_0)$. Moment t_0 is a collision moment. If the collision doesn't occur, the vehicle will be spontaneous damaged at the time t_k as a result of exceeding the allowable stress values for an element of operational stress. Moment of t_k can be treated as a withdrawal of the vehicle from the maintenance.

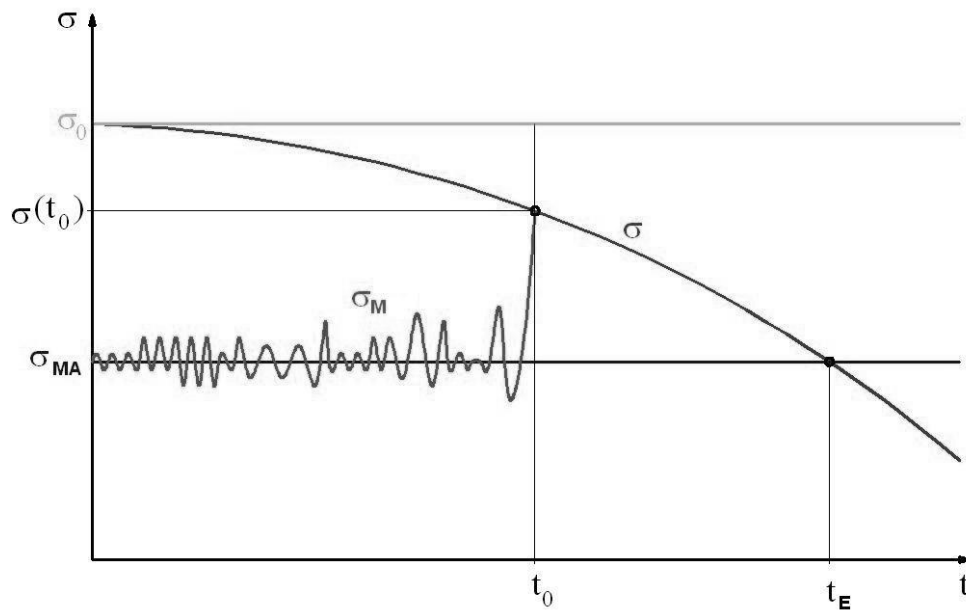

Fig. 3. Stress in the elements of the vehicle body as a function of time [based on 2 ÷ 5]
 Rys. 3. Naprężenia w elemencie nadwozia w funkcji czasu [na podstawie 2 ÷ 5]

If after crash an item is incorrectly repaired (fig. 3a), its permissible stress will be lower than the stress $\sigma(t_0)$. For this reason the next crash deceleration of the vehicle will be lower, however the vehicle body deformation will increase. It is disadvantageous due to possible deformation of the passenger compartment. In addition, when repairs were done incorrectly it may cause an early withdrawal to the vehicle from the maintenance (moment t_{ER}). If after the collision each item is properly fixed (fig. 3b), its allowable stress will be greater than the stress $\sigma(t_0)$. During the next collision the deceleration value will be greater, but vehicle body deformation will be smaller. There is a real possibility that it may have immense influence over life and health of the vehicle driver and passengers. In order to prevent that, the maximum of permissible stress for the repaired item can not be higher than allowable stress for the element of the vehicle provided by the manufacturer (σ_0 – value for new vehicle). It is true, that before introduction of the model of the vehicle on the market, the series of tests (including the crash) must be done.

It may be affirmed that allowable stress of the repaired element can't be less than allowable stress for the element before the moment of collision. In the same time allowable stress can't be greater than for a new element of the vehicle. This is shown on fig. 4 and in equation 1 (σ_R – permissible stress for the repaired element).

$$\sigma_R \in \langle \sigma(t_0), \sigma_0 \rangle \quad (1)$$

3. TESTS

In order to check the validity of all of the above studies investigation on real and model of vehicle body parts were conducted. The elements of the body vehicle were damaged on impact in short time. Next they were repaired using the mechanical methods. After that the repaired elements were destroyed by the next impact. Both deceleration and deformation were recorded during these impacts. During the studies were selected these elements of the vehicle body which were responsible for absorbing impact energy.

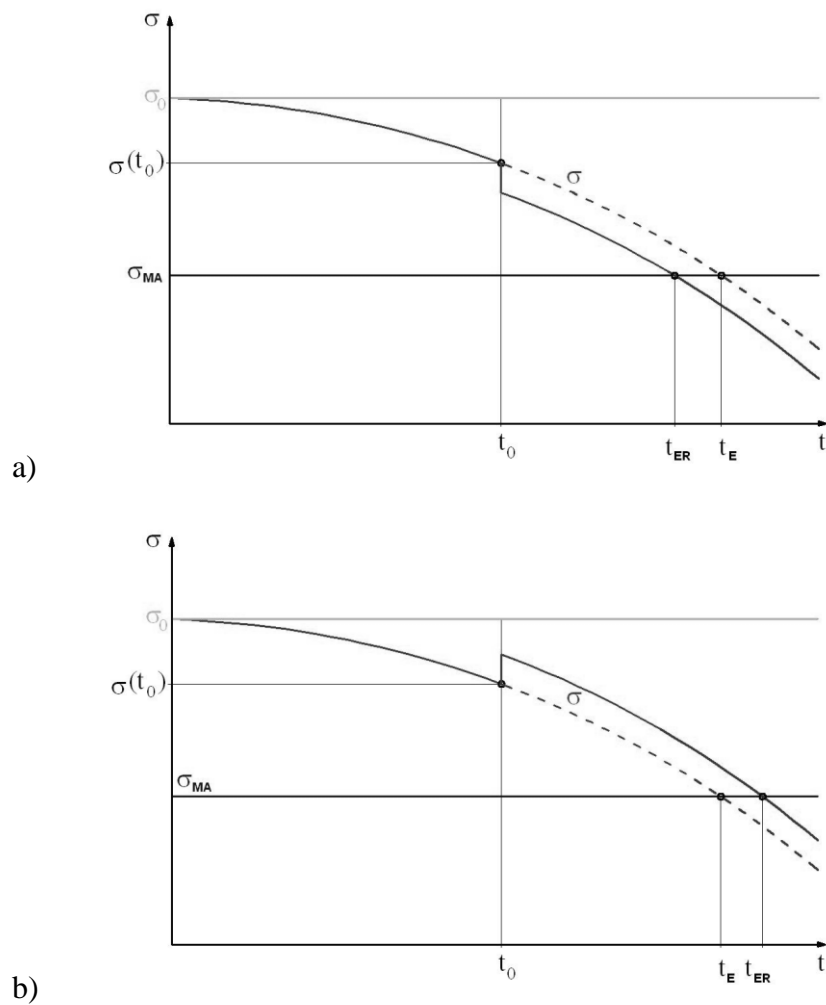

Fig. 4. Decline (a) and growth (b) the value of allowable stress for the repaired item
 Rys. 4. Spadek (a) i wzrost (b) wartości dopuszczalnego naprężenia dla elementu naprawionego

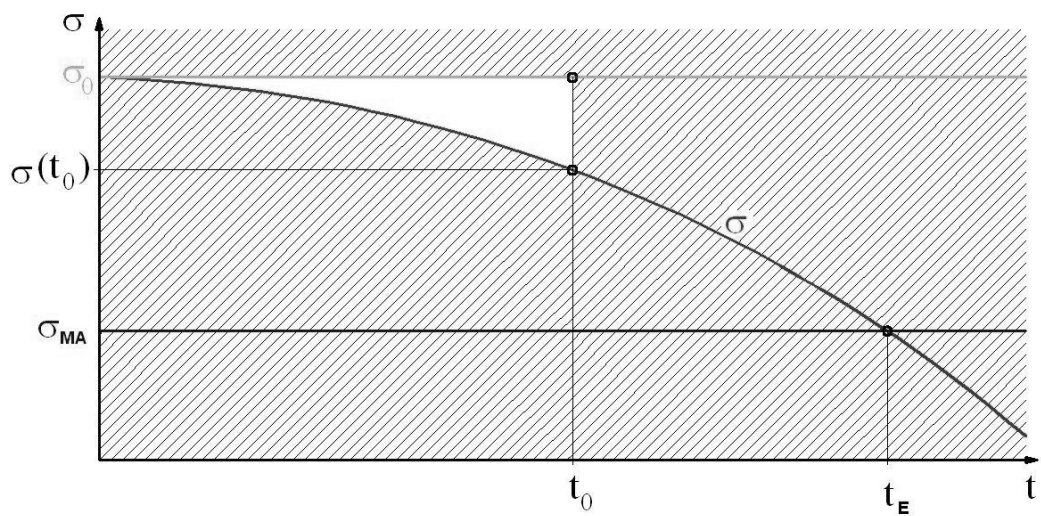

Fig. 5. Graphical representation of the performance criterion for repairs
 Rys. 5. Graficzne przedstawienie kryterium poprawności przeprowadzenia naprawy

The obtain results were shown in fig. 5 and 6 below. It can be observed that all repaired parts of the vehicle body have the different mechanical properties value in comparison with the new one. The result shows that the mechanical properties of the repaired elements (real and model) are worse in comparison with the properties of the elements obtained from the “original collision”. The straightened parts of the vehicle body have a smaller maximum of deceleration than the new elements. This decrease is about 44%. This change is not dangerous for a driver and for the passengers but it causes the changes in deformation of tested elements. The opposite situation occurred in the case of deformation of the tested elements. The repaired samples achieved a greater deformation during the second impact. This increase was about 92%. It may be very dangerous for a driver and for the passengers, because this may cause a decline in the volume of passenger compartment.

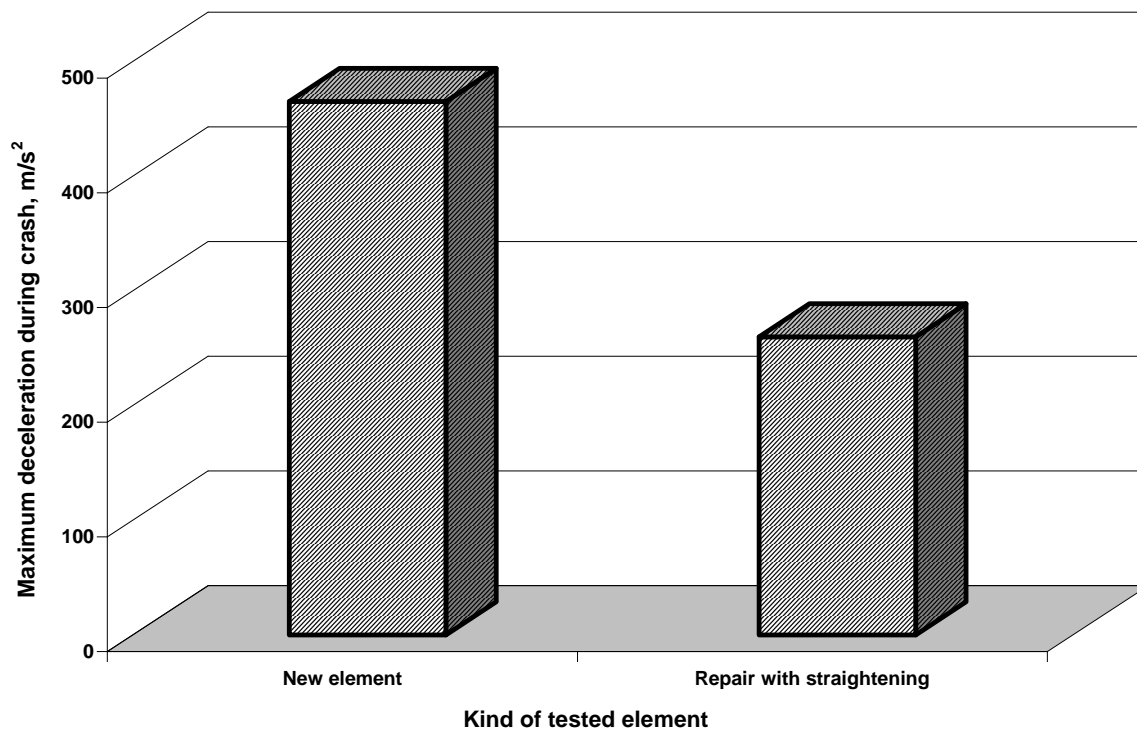

Fig. 6. The results of maximum deceleration for the new and for the repaired model elements of the car body

Rys. 6. Wyniki maksymalnego opóźnienia dla nowych i naprawionych modelowych elementów nadwozia pojazdu

4. CONCLUSION

Generally speaking, the technical condition of the vehicle and the correctness of the post-accident repairs have immense influence on the professional driver's safety. It is a very important problem, given that it relates both to the professional driver's safety and to the economy (the cost of repairs, compensation, absence in work). It was shown that a very important issue is the automotive criteria for the correctness of the post-accident repairs. Most of the automotive criteria are sufficient to secure a safe workplace for a professional driver. Therefore the most important automotive criteria for the post-accident repairs must be applied in order to ensure the safety of professional drivers. It is very important, because a professional driver spends many hours daily in the vehicle (very often being under stress), thus this professional requires a good and very safe conditions.

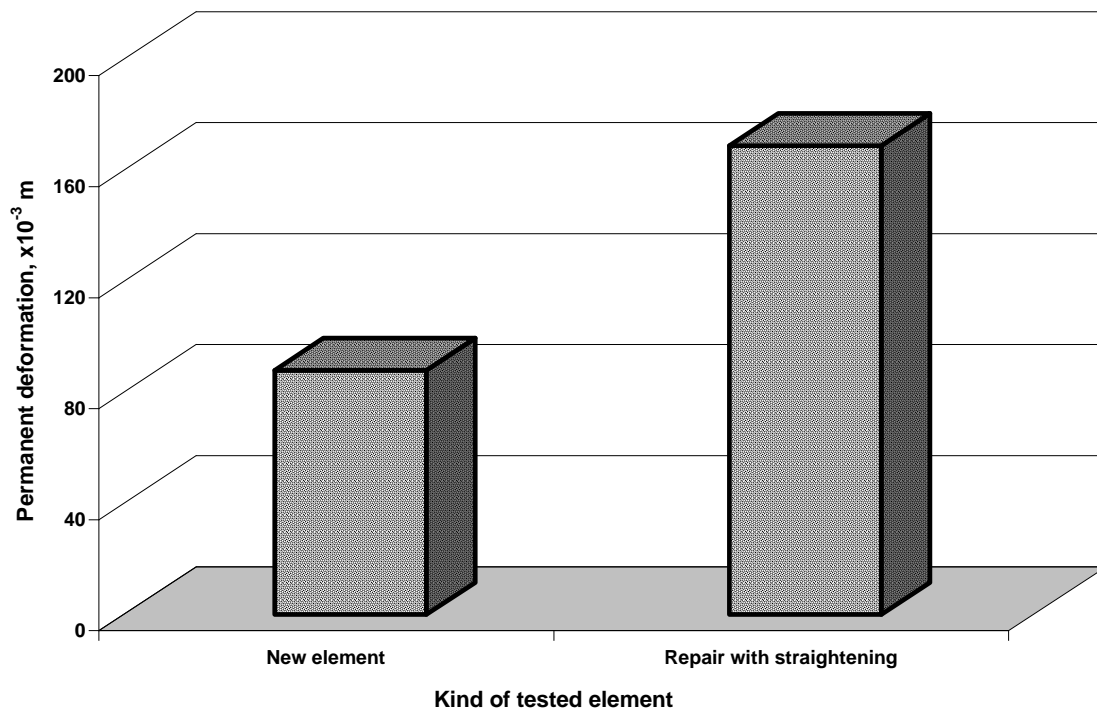

Fig. 7. The sample results of permanent deformation for new and repaired model elements of the car body

Rys. 7. Przykładowe wyniki wartości odkształcenia plastycznego dla nowych i naprawionych modelowych elementów nadwozia pojazdu

Bibliography

1. *CAR-O-LINER: Company data sheet – print from computer program Car-O-Soft 2000 V.1.56 for vehicle Fiat Punto 2000.*
2. Grosman F., Hadasik E.: *Technologiczna plastyczność metali. Badania plastometryczne*, Wydawnictwo Politechniki Śląskiej, Gliwice 2005.
3. Haviland R.P.: *Niezawodność urządzeń technicznych*, Państwowe Wydawnictwo Naukowe, Warszawa 1968.
4. Hebda M., Janicki D.: *Trwałość i niezawodność samochodów w eksploatacji*, Wydawnictwa Komunikacji i Łączności, Warszawa 1977.
5. Stricker L.A.: *Rola diagnostyki samochodowej w bezpieczeństwie jazdy*, Zeszyty Naukowe Politechniki Świętokrzyskiej, s. Mechanika z. 64, Kielce 1998, s. 153-162.

Received 12.06.2011; accepted in revised form 09.10.2012