

crankshaft, torsional damper, torsional stiffness, damping coefficient

Wojciech HOMIK

Rzeszow University of Technology, Faculty of Mechanical Engineering and Aeronautics
Al. Powstańców Warszawy 8, 35-959 Rzeszów, Poland
*Corresponding author. E-mail: whomik@prz.edu.pl

**INFLUENCE OF TEMPERATURE CHANGES ON TORSIONAL RIGIDITY
AND DAMPING COEFFICIENT OF RUBBER TORSIONAL VIBRATION
DAMPER**

Summary. The short explanation of usefulness of rubber torsional dampers in crankshaft in multi-cylinder engines is presented. The description of the construction and operation of rubber torsional damper is also included. In the rubber torsional damper, the damping is achieved as the effect of internal friction resulting from the deformation of the rubber material. This deformation appears while the internal rubber elasticity is overloaded. Both the physical and mechanical rubber properties depend on temperature change. In cooperation with rubber dampers manufacturer the experimental investigations are made in order to establish the influence of temperature change on torsional stiffness and damping.

**WPLYW ZMIAN TEMPERATURY NA SZTYWNOŚĆ SKRĘTNĄ
I WSPÓŁCZYNNIK TŁUMIENIA GUMOWEGO TŁUMIKA DRGAŃ
SKRĘTNYCH**

Streszczenie. W pracy zamieszczono krótkie uzasadnienie celowości stosowania w wielocylindrowych samochodowych silnikach spalinowych, tłumików drgań skrętnych wałów korbowych. Omówiono także budowę oraz zasadę działania gumowego tłumika drgań skrętnych. Gumowy tłumik drgań skrętnych jest tłumikiem, który tłumia drgania skrętne wału dzięki istnieniu wewnętrznego tarcia gumy podczas jej deformacji. Deformacja ta występuje w chwili, gdy zostanie pokonana sprężystość wewnętrzna gumy. Mając na względzie fakt, że właściwości fizyczne i mechaniczne gumy są bezpośrednio związane ze zmianą temperatury, we współpracy z producentem gumowych tłumików drgań skrętnych zostały przeprowadzone badania, których celem było ustalenie wpływu zmian temperatury na sztywność skrętną i tłumienie tłumika. Wyniki badań i ich analizę zamieszczono w niniejszej pracy.

Disadvantageous effect of torsional vibrations of crankshafts in combustion engines can be considerably limited by application of torsional vibration dampers. In motor-car combustion engines such a damper is located as a rule on a free end of the crankshaft and it is built-in in a belt pulley [1] transmitting the power to other subassemblies of the engine (fig. 1).

In motor-car combustion engines, particularly those used to drive passenger cars the rubber torsional vibration dampers are used. A typical is made up of inertial ring joint to the boss with a layer of rubber [2, 3] of suitable hardness, elasticity and damping coefficient (fig. 2).

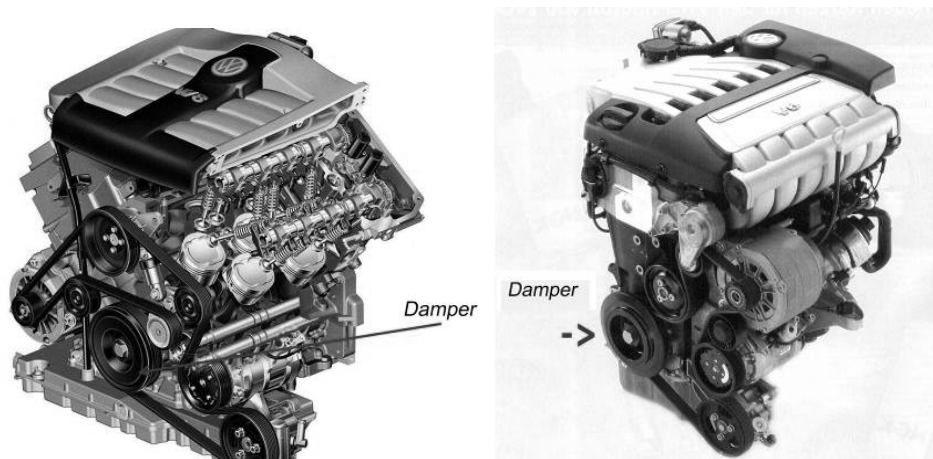

Fig. 1. VW brand motor-car engines with torsional vibration dampers assembled
Rys. 1. Samochodowe silniki marki VW z zamontowanymi tłumikami drgań skrętnych

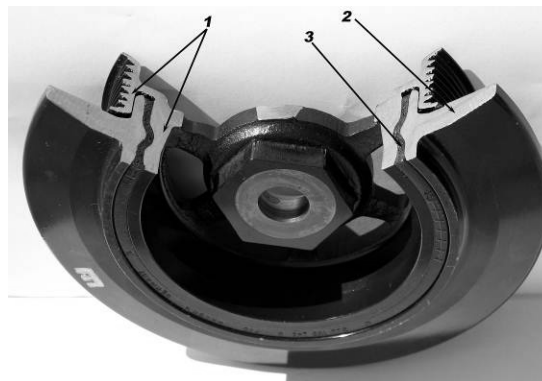

Fig. 2. Rubber torsional vibration damper made by DAMPOL company: 1 – boss, 2 – inertial ring, 3 – rubber damping element

Rys. 2. Gumowy tłumik drgań skrętnych produkowany przez firmę DAMPOL: 1 – piasta, 2 – pierścień bezwładnościowy, 3 – gumowy element tłumiący

The damper of such type dampens resonant torsional vibrations of engine crankshaft thanks to internal friction of rubber during its deformation. This deformation occurs while internal elasticity of rubber is overcome (then the relative motion between the boss and the inertial ring occurs). It takes place in case of exceeding certain torsional vibration amplitude of the crankshaft and loading the rubber with torque moment M . Torque moment M makes rubber is sheared and shear stress occur in it, whose value depends on radius R of considered rubber layer (fig. 2, 3).

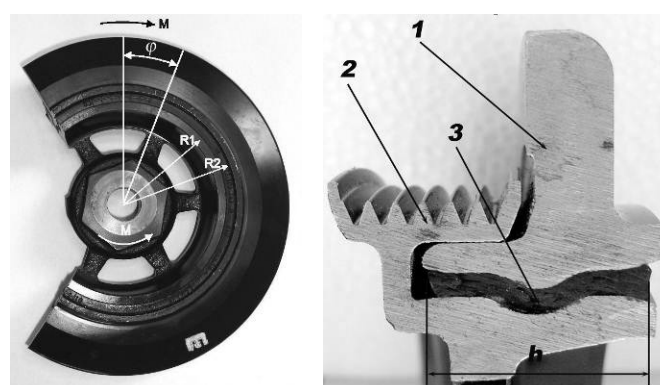

Fig. 3. Rubber torsional vibration damper made by DAMPOL company – geometric parameters: 1 – boss, 2 – inertial ring, 3 – rubber damping element

Rys. 3. Gumowy tłumik drgań skrętnych produkowany przez firmę DAMPOL - parametry geometryczne; 1 – piasta, 2 – pierścień bezwładnościowy, 3 – gumowy element tłumiący

Assuming that cross-sectional area of rubber is a rectangle with side h (what is obviously certain simplification), shear stress value equals [4]:

$$\tau = \frac{P_t}{A} = \frac{M}{2\pi R^2 h} [\text{MPa}]$$

where: P_t – shearing force, A – cross-section area of rubber, M – torque moment, R – radius of considered rubber layer, h – width of rubber ring. At slight values of torque moment M and thus at slight distortions of rubber, angle φ in considered rubber layer amounts to:

$$\varphi = \frac{M}{4\pi h G} \left(\frac{1}{R_1^2} - \frac{1}{R_2^2} \right) [\text{rad}]$$

where: G – modulus of volume elasticity of rubber [MPa].

The shape of cross-section of rubber in rubber torsional vibration dampers is practically optional. However one should remember that with suitable configuration of damping element, which is simultaneously a connecting member of the boss and the inertial ring, one can achieve uniform shear (tangential) stress pattern in whole cross-section of rubber during work of the damper and thus its increase in resistance to fatigue.

In order to be equal to this task, at the stage of design of damper profiles mating directly with rubber connecting member one should to remember about the condition [4]:

$$\tau = \text{const} \Leftrightarrow R^2 h = \text{const}$$

Since this condition is difficult to accomplish, the process of rubber vulcanization enabling connection of damper elements is replaced by the process of forcing the rubber – the rubber ring is pushed into a gap between the boss and the inertial ring.

Theoretically, at selection (design) of a rubber damper for a given engine type, one has a relative freedom in the matter of change of particular parameters affecting its characteristic (fig. 4) [5], thus one can change mass moment of inertia of the ring, the shape and cross-section dimensions of rubber, and physical properties of rubber.

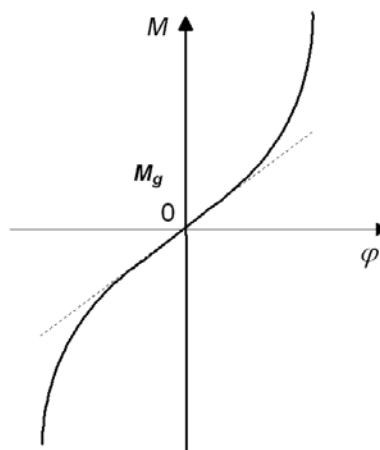

Fig. 4. Characteristic of rubber vibration damper
Rys. 4. Charakterystyka gumowego tłumika drgań

Practical life of rubber vibration damper used in passenger car engines amounts to 150 000–180 000 kilometers. These dampers are disposable parts and are not subject to regeneration.

Before starting designing or selection of torsional vibration damper for a given engine one should make dynamic tests, that is to carry out the harmonic analysis of torsional vibrations of engine crankshaft without a damper.

Such an analysis allows to determine resonant frequencies of the engine and thus to determine force frequency for the designed damper. For such frequency a damper is being designed whose task after assembling on a crankshaft is to eliminate its work in resonance. At designing the rubber torsional vibration damper we must remember that properties of rubber, in contrast to other materials

are subject to change under the influence of external factors (temperature, dynamic loads). Among basic physical-mechanical properties of rubber we count [4, 6]:

- ◆ hardness of rubber,
- ◆ elasticity of rubber,
- ◆ resistance to ageing,
- ◆ thermal resistance,
- ◆ absorbing and diffusive power – vibration damping,
- ◆ creep and relaxation of rubber,
- ◆ tensile, compression and shear strength,
- ◆ thermal and electrical properties.

In dynamic systems working at periodically variable input force, such as rubber torsional vibration damper works in, behavior of rubber is represented by a graph placed in fig. 5 [4].

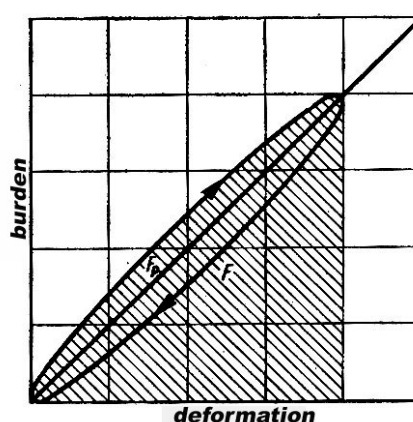

Fig. 5. Hysteresis loop at dynamic load of rubber (dynamic damping loop)

Rys. 5. Pętla histerezy przy dynamicznym obciążeniu gumy (dynamiczna pętla tłumienia)

The increasing and decreasing deformation curves do not cover themselves, but they generate the hysteresis loop of a shape similar to an ellipse called repeatedly a damping loop. The graph area under the curve of increasing deformations constitutes a measure of absorbed energy and ellipse area is a measure of energy changed to heat. The ratio of these areas, expressed in percentage, is called rubber damping index:

$$D = \frac{F_p}{F}$$

During periodically variable input force the springing constant is subject to increase and it equals:

$$c_{dyn} = k c$$

where : c_{dyn} – dynamic springing constant, c – springing constant, k – stiffening coefficient.

Stiffening coefficient „ k ” depends on rubber hardness, its value equals from 1 to 3 and most often is read out of the graph (fig. 6) [4].

Attempts of mathematical description of rheological processes proceeding in rubber have demonstrated that sufficient approximation to reality is given by complex Maxwell’s models – parallel and Kelvin-Voigt’s ones – serial (fig. 7) [6].

One of basic faults of rubber is high sensitivity of mechanical properties of that material to temperature changes. Changes of physical and mechanical properties of rubber in torsional vibration damper are related not only to variable ambient temperature but also to heat release as a result of occurrence of periodically variable dynamic input forces. Depending on damping, amplitude and vibration frequency, portion of energy is changed to heat, producing considerable temperature increase of rubber damping element.

In order to determine influence of temperature changes on torsional rigidity and damping in a serially produced by DAMPOL company torsional vibration damper (fig. 2), research was carried out

– a damper with rubber hardness 70° [ShA] was examined. The investigations were carried out on a test stand (fig. 8) for two values of damper working temperature: 25° [C] and 60° [C]. In both cases the damper was loaded and unloaded with the same values of torque moment.

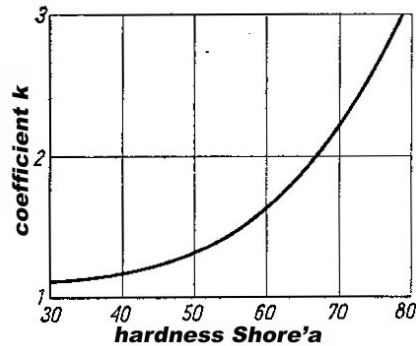

Fig. 6. Rubber stiffening coefficient as a function of Shore'a hardness

Rys. 6. Współczynnik usztywnienia gumy w funkcji twardości Shore'a

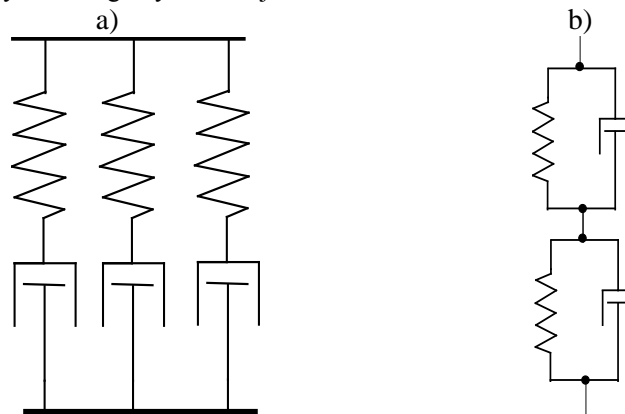

Fig. 7. Rubber models: a) Maxwell's model – parallel, b) Kelvin-Voigt's model – serial

Rys. 7. Modele gumy: a) model Maxwella – równoległy, b) model Kelwina-Voigta – szeregowy

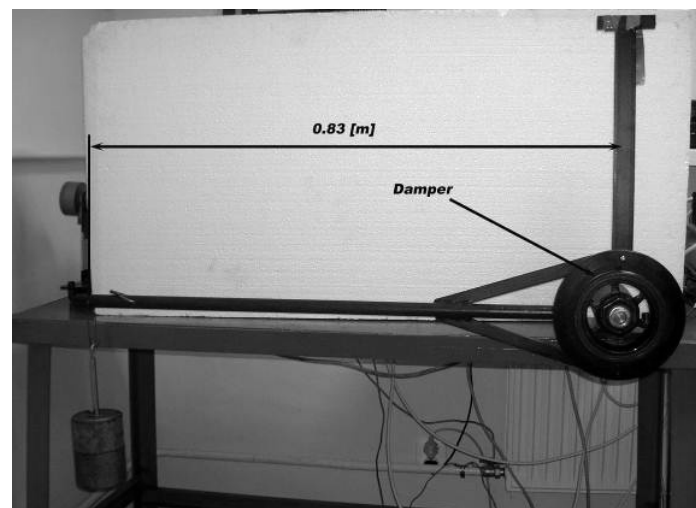

Fig. 8. Test stand

Rys. 8. Stanowisko badawcze

The results are presented in table 1 and in fig. 9.

Table 1

| Torque moment [Nm] | Torsional angle [deg] temperature 25° [C] | | Torsional angle [deg] temperature 60° [C] | |
|--------------------|---|-----------|---|-----------|
| | loading | unloading | loading | unloading |
| 0 | 0 | 0,28525 | 0 | 0,978 |
| 24,4269 | 0,2445 | 0,652 | 0,326 | 1,467 |
| 40,7115 | 0,44825 | 0,978 | 0,7335 | 1,956 |
| 61,0673 | 0,69275 | 1,2225 | 1,141 | 2,3635 |
| 77,3519 | 0,93725 | 1,467 | 1,467 | 2,6895 |
| 85,4942 | 1,2225 | 1,7115 | 1,8745 | 3,0155 |
| 111,55 | 1,63 | 1,956 | 2,445 | 3,3415 |
| 140,048 | 2,119 | 2,119 | 3,6 | 3,6 |

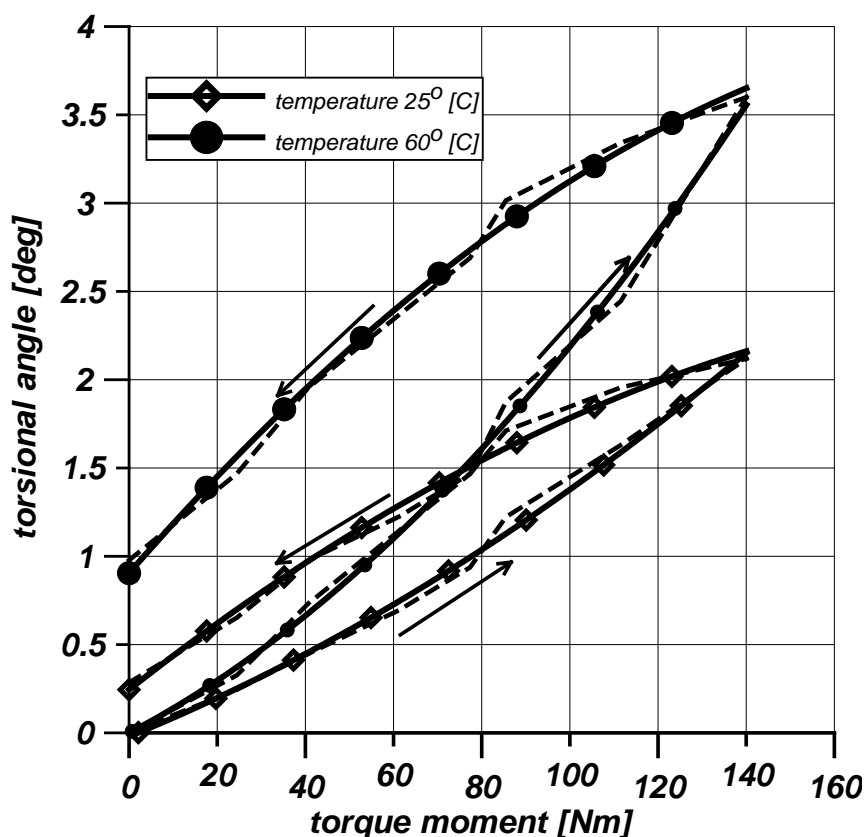

Fig. 9. Courses of hysteresis loop of rubber torsional vibration damper obtained in experimental way – investigation carried out on a serially produced vibration damper in DAMPOL company

Rys. 9. Przebiegi pętli histerezy gumowego tłumika drgań skrętnych otrzymane na drodze doświadczalnej - badania przeprowadzone a seryjnie produkowanym tłumiku drgań w firmie DAMPOL

It results from the obtained damping loops that together with working temperature increase there were subject to change: the torsional rigidity of a damper, percentage damping index as well as relative damping called also relative damping index.

Values of above mentioned quantities for the tested rubber damper equal:

$$k_{s25} \approx 0.41 \cdot 10^4 \left[\frac{\text{Nm}}{\text{rad}} \right] - \text{torsional rigidity of the damper at } 25^\circ \text{ [C]}$$

$$k_{s60} \approx 0.25 \cdot 10^4 \left[\frac{\text{Nm}}{\text{rad}} \right] - \text{torsional rigidity of the damper at } 60^\circ \text{ [C]}$$

$D_{25} \approx 0.335$ - damping index of the damper at 25° [C]

$D_{60} \approx 0.264$ - damping index of the damper at 60° [C]

$\Psi_{25} \approx 1.6$ - relative damping of the damper at 25° [C]

$\Psi_{60} \approx 1.21$ - relative damping of the damper at 60° [C]

Working temperature increase of the damper by 35° [C] caused torsional rigidity decrease of the damper by approx. 39% as well as relative damping decrease by approx. 22.5%.

The carried out investigation have proven that working temperature increase of a damper affects its working characteristic. Together with working temperature change operating parameters are also subject to change, thus its performance is also subject to change. These changes last to the moment of achieving so called saturation temperature by the damper. Taking the above into consideration in justified cases one should reflect on application of broad-band torsional vibration damper e.g. viscosity torsional vibration damper filled with MR liquid [7, 8, 9, 10].

References

1. Niewiarowski K.: *Piston combustion engines*. WKiŁ Warsaw 1968.
2. Homik W., Skrzat A.: *Strength analysis of the torsional vibration damper with internal damping*. XXIII Sympozjon Machinery Elements Design, t.1, Rzeszów, Przemysł, 2007, s. 209-217.
3. Homik W.: *Torsional vibrations of engine crankshaft with rubber vibration damper*. XVIII International Conference – SAKON Computational and research methods in the development of automotive vehicles and self-propelled working machines. Rzeszów 2007, pp. 107-114.
4. Jaworski J.: *Rubber in automotive vehicles*. WKiŁ, Warsaw 1967.
5. Osinski Z.: *Damping of torsional vibrations*. PWN, Warsaw 1986.
6. Pękala M., Radkowski S.: *Rubber elastic elements*. PWN, Warsaw 1989
7. Homik W.: *Analysis of torsional vibrations of the shaft with taking into account the rheologic vibration damper*. XXII Sympozjon Machinery Elements Design, t.3, Gdynia, 2005, s. 95-102.
8. Homik W.: *Damping analysis in torsional vibration damper with taking into account the rheologic liquid.*, XII Sympozjon Construction Dynamics, Rzeszów, 2005, s. 159-166.
9. Homik W.: *Influence of flow limit in Bingham liquid model on vibration damping*. XVI International Conference – SAKON Computational and research methods in the development of automotive vehicles and self-propelled working machines, Rzeszów 2005, s. 133-138.
10. Homik W.: *Application of rheologic liquids in technology, and particularly in mechanical vibration damping*, Przegląd Mechaniczny 10' 06, s. 29-31.

Received 5.02.2010; accepted in revised form 25.03.2011